

Vent-Axia®

Sentinel Econiq S MVHR

Installation and User Guide Instructions

Original instruction



Stock Ref. N°

499883 - Sentinel Econiq S

411077 - Sentinel Econiq SC

499890 - Sentinel Econiq SCP RH

499891 - Sentinel Econiq SCP LH



**PLEASE READ THESE INSTRUCTIONS CAREFULLY
BEFORE COMMENCING INSTALLATION OR OPERATION.**

**PLEASE REFER TO ACCOMPANYING DOCUMENTATION
FOR INFORMATION SPECIFIC TO YOUR UNIT.
PLEASE RETAIN THESE INSTRUCTIONS WITH THE
PRODUCT.**



Warnings and Safety Information

- Do not install this product in areas where the following may be present or occur:
 - Excessive oil or a grease laden atmosphere.
 - Corrosive or flammable gases, liquids or vapours.
 - Subject to direct water spray from hoses.
 - Ambient temperatures higher than 40°C and lower than -20°C.
 - Possible obstructions that may hinder access to or removal of the unit.
- All wiring must be in accordance with the current IET wiring regulations BS7671, or appropriate standards of your country. Installation should be inspected and tested by a suitably qualified person after completion.
- Ensure the mains supply (voltage, frequency and phase) complies with the rating label.
- The unit should be provided with a local double pole fused spur fitted with a 3A fuse having a contact separation of at least 3mm. If a unit fitted with a preheater is being installed, a 13A fuse should be used.
- These units must be earthed.
- Precautions must be taken to avoid the backflow of gases into the building from the open flue of gas or other fuel-burning appliances.
- This appliance is not intended for use by persons (including children) with reduced physical, sensory or mental capabilities, or lack of experience and knowledge, unless they have been given supervision or instruction concerning use of the appliance by a person responsible for their safety.
- Young children should be supervised to ensure that they do not play with the appliance.
- The installer is responsible for the installation and electrical connection of the MVHR system on site. It is the responsibility of the installer to ensure that the equipment is safely and securely installed and left only when mechanically and electrically safe.
- All regulations and requirements must be strictly followed to prevent hazards to life and property, both during and after installation, and during any subsequent servicing and maintenance.
- The unit's condensate drain must be connected to the building's wastewater drainage system.
- Certain applications may require the installation of sound attenuation to achieve the sound levels required.
- The unit must not be connected directly to a tumble drier.
- The supply and exhaust valves must be fully opened prior to commissioning.
- The intake air must be drawn from the exterior of the property.
- The unit should be allowed to stabilise during commissioning for a minimum period of 5 minutes when changing between boost and normal speeds.
- External grilles should be positioned in accordance with your local building regulations, however as a minimum we recommend that the inlet grille is kept 2m from any discharge grille or flue outlet.
- This product and associated duct installation should be carried out in accordance with the Domestic Ventilation Compliance Guide.

UK Building Regulations (Part F) Declaration of Conformance

The unit conforms to the 2010 Building Regulation (Part F - Means of Ventilation, F1(1), F(2)) requirements for fixed systems for mechanical extract fans when installed in accordance with the instructions in this document and the Domestic Ventilation Compliance Guide.

Product Description	4
Installation	5
Overview	5
Wall mounting a Unit	6
Floor mounting a Unit	7
Floor mounting a Unit (Alternate Method)	8
Vertical Discharge Condensate Installation	9
Attaching the Ducting	10
Connecting the Power Supply	11
Accessing the Mains PCBA	12
Connecting a Boost (Light) Switch from a different circuit, Controllers and Sensors	13
Operating and Monitoring	15
Powering up the Unit	15
Initialisation/Loading Screen	15
Serial number on initialisation	15
Overview	16
Display overview – Home screen	16
Home user menu	17
Display overview – Additional icons	17
Display overview – Mode indicators	18
Display overview – Indoor air quality monitor	18
Display overview – Heat Recovery mode	19
Smart Device Pairing and App Download	19
Pairing sensors	20
Removing sensors	20
Speed Override	21
Schedule	21
Filter Reset	22
Warning Screen	22
Service Interval Remaining	22
Notifications if any	22
Engineer menu	23
Engineer menu – Overview	23
Engineer menu – Unit Handing	24
Engineer menu – Airflow units	24
Engineer menu – Airflow speed setting	25
Engineer menu – Port allocation LS	25
Engineer menu – Port allocation SW	26
Engineer menu – Proportional control	26
Engineer menu – Service Intervals	27
Engineer menu – Summer bypass	27
Engineer menu – Humidity	28
Engineer menu – CO2 threshold	28
Engineer menu – Date / Time	29
Engineer menu – PIN Change	29
Engineer menu – Default settings	30
HMI Hard Reset	30
Maintenance	31
Filter Maintenance	31
Periodic Maintenance	32
Spares	33
Diagnosing a Problem	34
Power on Self-Test – HMI	35
Power on Self-Test – Mainsboard	35
Accessories	36
Wall-Mounting HMI Kit	36
Remote LED Indicator	36
Technical Data	37
Flow Rate settings	37
Frost Protection	37
Summer Bypass Mode	38
Product Dimensions	39
Default settings	40
Product Fiche	41
Disposal	44
The Guarantee/Claim on Warranty	44
Contact Details	44

Product Description

Mechanical Ventilation/Heat Recovery (MVHR). This heat recovery unit is designed for the energy efficient ventilation of houses and similar dwellings, conforming to the latest requirements of the Building Regulations document F 2010.

The unit is designed for continuous 24-hour extract ventilation of stale moist air from bathrooms, toilets, utility rooms and kitchens. As the stale air is extracted, a heat exchanger within the unit transfers up to 93% of the extract air's heat, into the supply air entering the bedrooms and lounge. This provides significant energy recovery, reducing household heat costs, and providing the optimum comfort conditions.

In addition, some models will have features that maintain a constant airflow independent of the blocked filters.

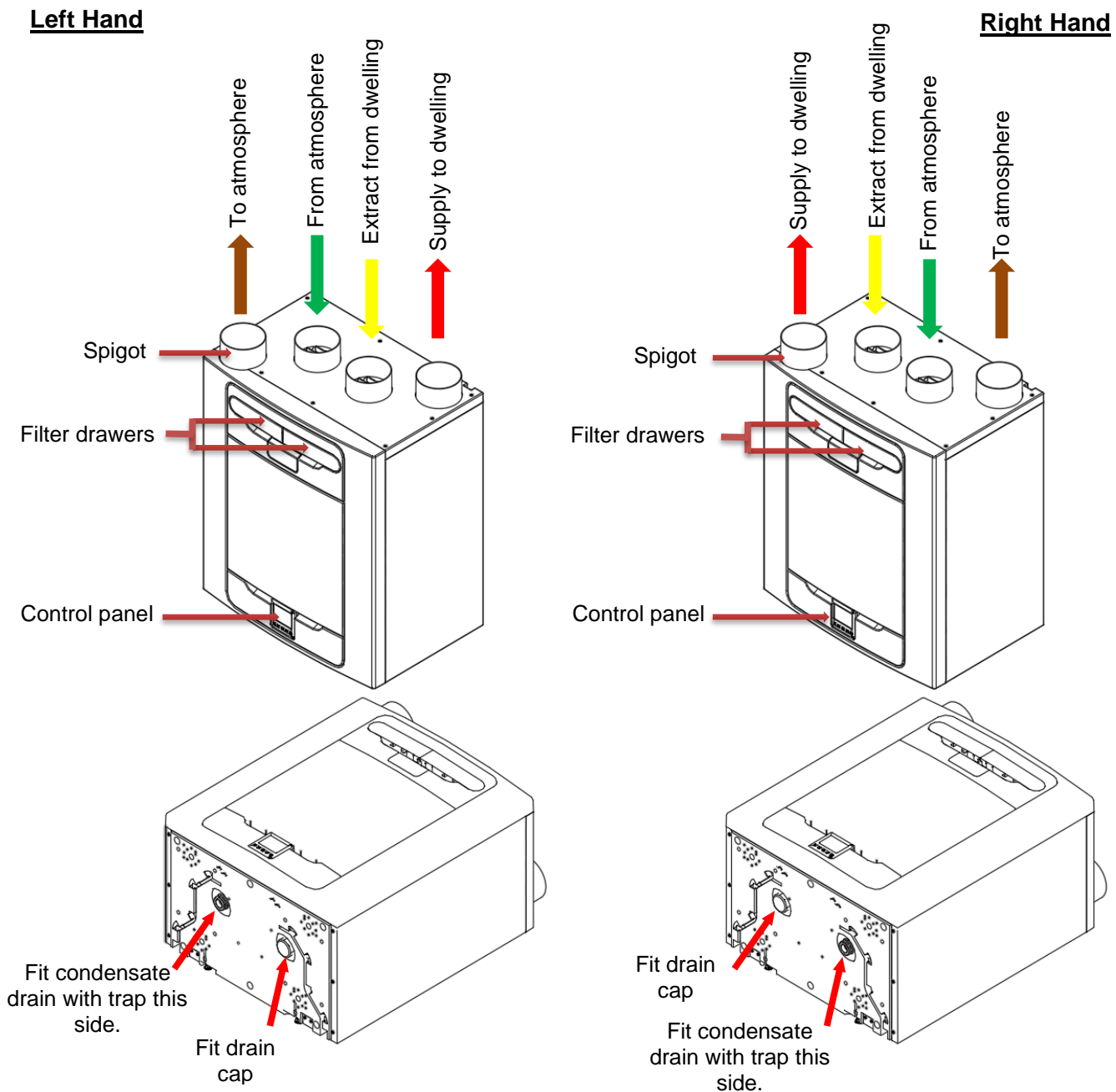

MVHR with Left-Hand and Right-Hand spigot configuration. Units with a preheater are preconfigured from the factory and the handing cannot be changed.

Overview

Before installation of the unit

We advise installers to fix all mains and sensor wiring along with any internal accessories prior to fixing the MVHR unit in position, leaving approximately 500mm tails to allow for internal routing.

Inspect the Unit

When taking delivery of the unit, check the items delivered against the enclosed delivery note. Inspect the unit for damage in transit. If in doubt, contact Customer Services. Each box contains a heat recovery unit, a wall bracket and accessory pack containing miscellaneous fixings and product documentation.

Unit Installation

Installation should be carried out by a suitably qualified and competent person.

If the unit is wall mounted, the wall should have sufficient strength to support the unit.

The unit may also be floor mounted, either directly to the floor or using standard kitchen cabinet feet (not supplied). Ensure that the unit is mounted upright.

Do not use this unit as a support for any other equipment.

Service Void

Clearance must be left around the unit to allow for cleaning and servicing, the dimensions below are the minimum requirements. The condensate drain trap used will dictate the necessary clearance below the unit which may be larger than the minimums.

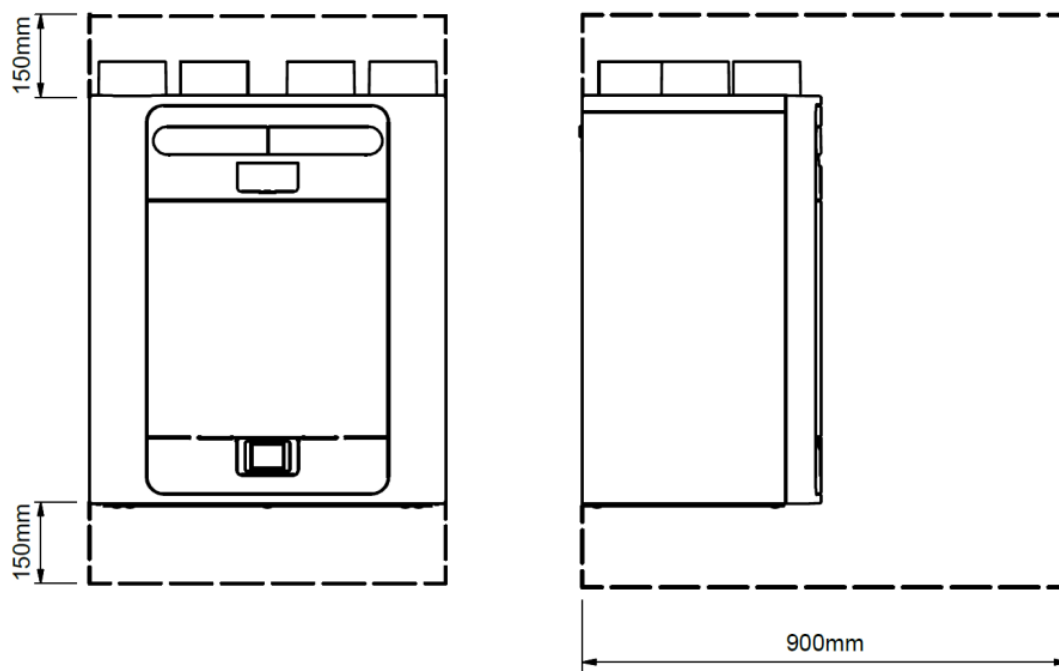

Select Unit Configuration

The unit is configurable as either Left or Right-Handed (Default), see page 4 for the spigot configuration. Use the Left-hand condensate drain for the Left-Hand configuration, the Right-hand drain for the Right-Hand configuration. If the unit is fitted with a preheater, the configuration is factory set.

Wall Mounting the Unit

Step 1: Mark the wall bracket position using the dimensions shown. Note the position of the top of the unit in relation to the wall bracket. Ensure the bracket position is horizontal.

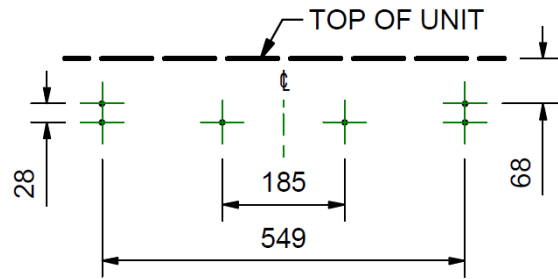

Step 2: Attach the wall bracket, using appropriate fixings.

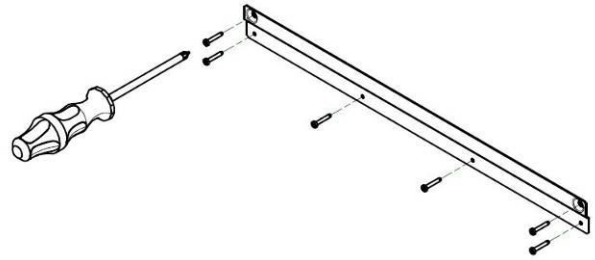

Step 3: Lift the unit and locate the two hooks on the rear onto the wall bracket.

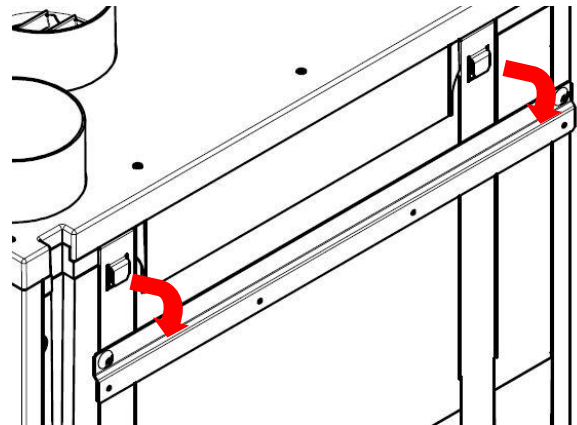

Step 4: Make sure the unit is level or leaning slightly backwards; this is to ensure the condensate drain functions correctly.

The mounting feet at the base of the unit are adjustable. From the factory, the mounting feet are set to compensate for the standoff caused by the mounting bracket. Adjust the feet in or out to level the unit as necessary.

If mounting on uneven walls, the spacers (A) may need to be removed before the feet can be screwed further into the unit. Lock the mounting feet into their final position using the M6 nuts (B).

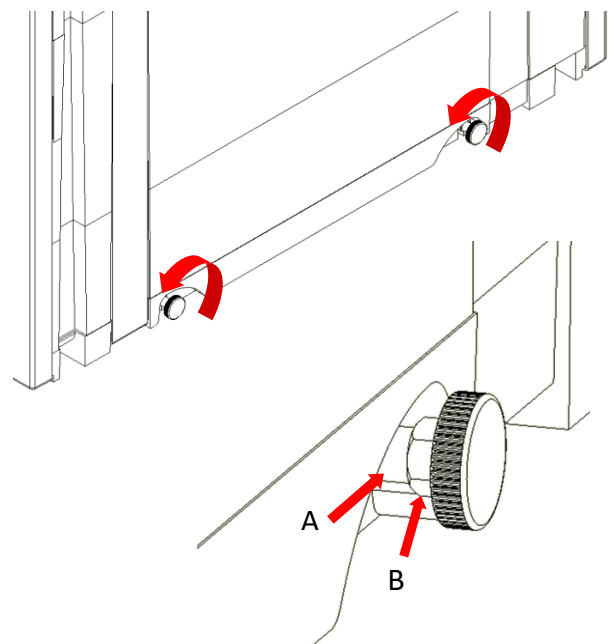

Floor Mounting the Unit

Step 1: The unit has 44 x 12mm deep fixing holes on the underside suitable for a No.6 screw. Predrill a board using the dimensions shown and cut 2 x 105mm minimum diameter holes for the condensate drain access.

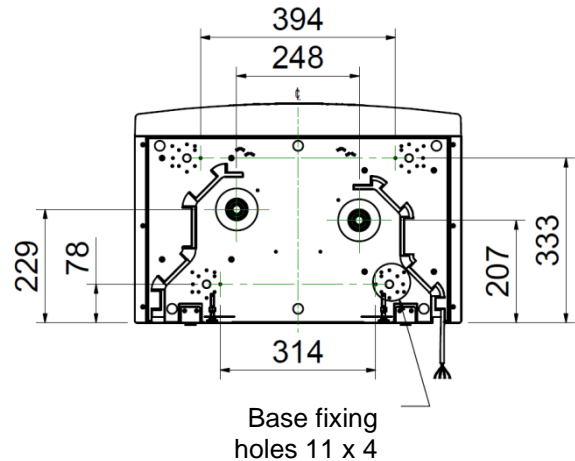

Step 2: Mount the board to the underside of the unit using appropriate fixings.

Note: Ensure any other cabling requirements (e.g., sensor, control cables etc) are routed through the back box on rear of the unit prior to mounting the board.

The board may then be attached to joists, flooring, or equivalent.

Vent-Axia recommends that where possible, the wall bracket is used in conjunction with any floor mount solution to prevent the unit from tipping.

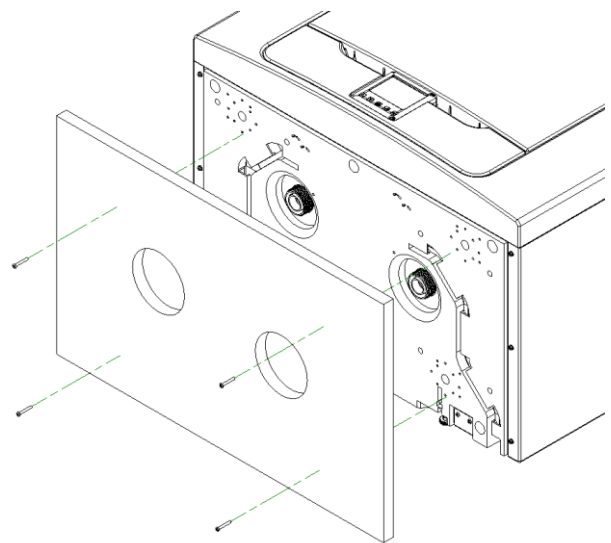

Step 3: Mark the wall bracket position using the Dimensions shown. Note the position of the top of the unit in relation to the wall bracket. Ensure the bracket position is parallel to the floor.

Step 4: Attach the wall bracket to the wall or batten using appropriate fixings. (As shown on page 6)

Step 5: Lift the unit and locate the two hooks on the rear onto the wall bracket prior to fixing the unit to the floor. (As shown on page 6).

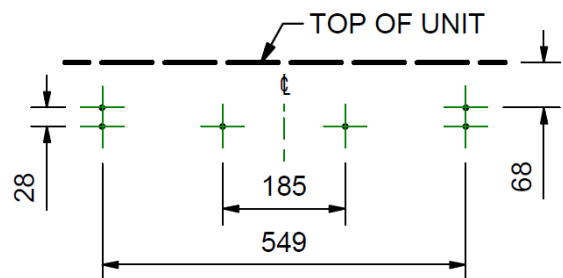

Floor Mounting the Unit (Alternate Method)

Step 1: The unit has 44 x 12mm deep fixing holes on the underside suitable for a No.6 screw. The holes are configured to allow fitment of most standard kitchen foot types (not supplied).

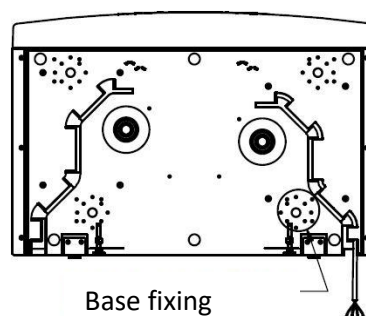

Step 2: Mount your chosen foot type to the underside of the unit using appropriate fixings.

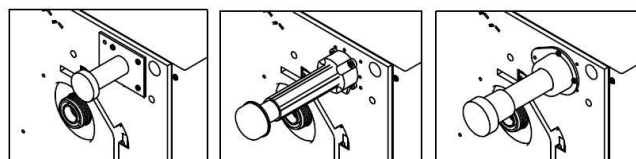

Step 3: Adjust your chosen foot type to ensure the base of the unit is horizontal in both axis.

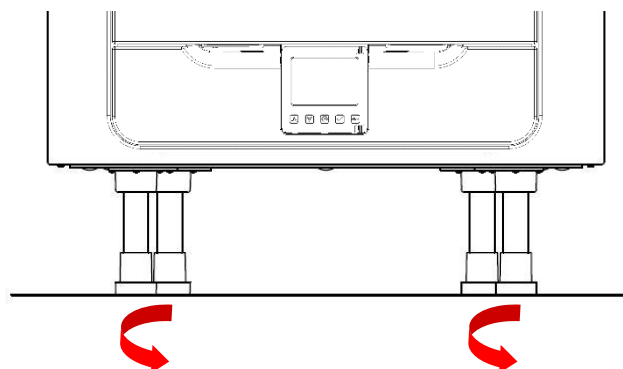

It is recommended that where possible, the wall bracket is used in conjunction with any floor mount solution to prevent the unit from tipping.

Step 4: Mark the wall bracket position using the dimensions shown. Note the position of the top of the unit in relation to the wall bracket. Ensure the bracket position is parallel to the floor.

Step 5: Attach the wall bracket to the wall or batten using appropriate fixings. (As shown on page 6)

Step 6: Lift the unit and locate the two hooks on the rear onto the wall bracket prior to fixing the unit to the floor. (As shown on page 6).

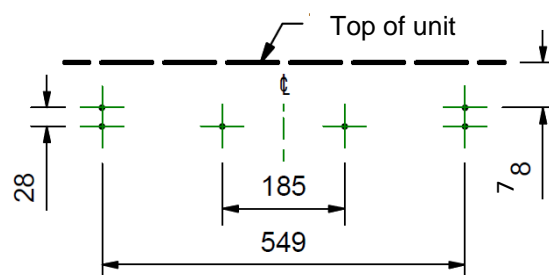

Vertical Discharge Condensate Installation

Note:

A trap must be fitted between the condensate drain of the unit and the rest of the waste system.

A waterless trap is recommended, as they are not susceptible to drying out during warmer periods when no condensate is formed. An example of a suitable waterless trap is the Osma HepVo waterless trap.

If a conventional trap is used, a trap with a minimum water seal of 60mm must be selected.

The condensate outlet is compatible with standard 22 mm plastic solvent weld fittings and 32mm threaded waste pipe fittings. Wastepipes must have a 3-degree minimum angle to allow the water to drain away from the unit naturally.

In areas where freezing weather conditions occur, outlet pipes must be insulated to avoid blockage by ice, which may cause damage to the unit and surroundings.

This guide shows a Right-Hand configuration for illustration.

If the unit is configured as Left Hand, then the condensate drain should be installed on the left with the blanking cap on the right

22mm waste pipe

Fit a waterless trap, or a conventional trap with a water seal of at least 60mm, close to the unit.

An adaptor can be used to adapt from 32mm to 22mm connections.

Fit the blanking cap supplied with the unit to the appropriate side, depending on the handing, see page 4. Ensure the sealing gasket is fitted inside the blanking cap.

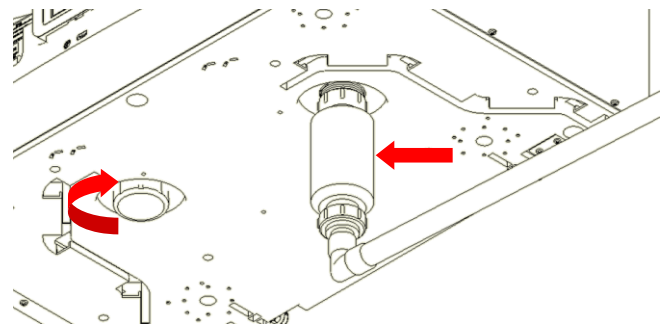

32mm waste pipe (recommended)

Fit a waterless trap, or a conventional trap with a water seal of at least 60mm, close to the unit.

Fit the blanking cap supplied with the unit to the appropriate side of the unit, depending on the handing of the unit, see page 4. Ensure the sealing gasket is fitted inside the blanking cap.

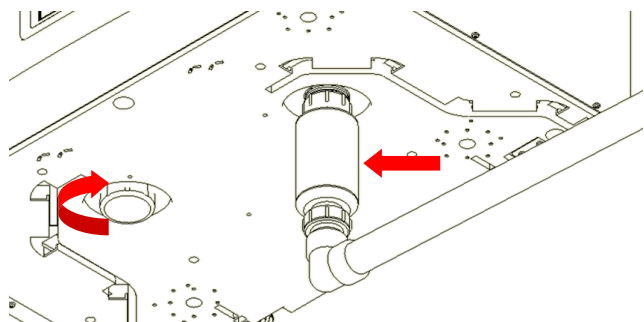

Attaching the Ducting

1. If using Insulated flexible duct this should not exceed 500mm in length, please refer to your local building regulations.
2. Securely connect the ducting to the spigots using worm-drive clips or suitable plastic ties.
3. Insulate any ducting passing through an unheated space to prevent any heat losses or surface condensation.
4. Insulate all ducting to and from outside vents.

All ducting should be installed in accordance with your local building regulations and best practice.

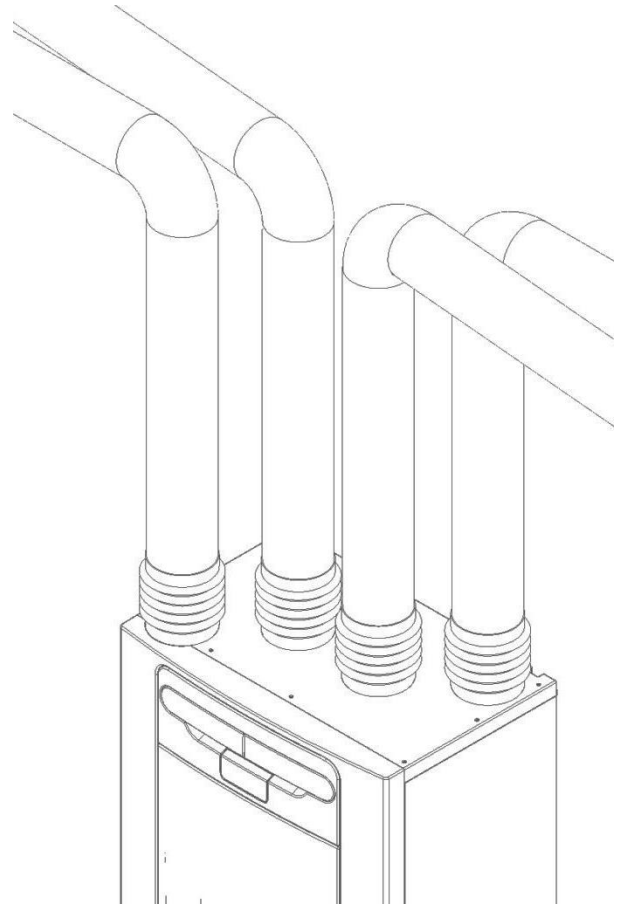

Connecting the Power Supply



WARNING

1. MAINS SUPPLY VOLTAGES (220-240V AC) ARE PRESENT IN THIS EQUIPMENT, WHICH MAY CAUSE DEATH OR SERIOUS INJURY BY ELECTRIC SHOCK. ONLY A SUITABLE QUALIFIED PERSON SHOULD CONNECT THE POWER SUPPLY TO THIS UNIT.
2. THIS UNIT MUST BE CORRECTLY EARTHED.
3. ALL EXTERNAL WIRING MUST BE FIXED WIRING.

This unit is designed for operation from a single-phase alternating current source (220-240V AC).

A 1.5m cable is connected internally to the unit for connection to an isolator switch.

If the supply cord is damaged, it must be replaced by a special cord or assembly available from the manufacturer or its service agent.

To connect the power supply:

Ensure the local AC power supply is switched off.

One end of the power cable has already been terminated within the unit.

Connect the other end of the cable to a switched fused spur as shown.

The switch fused spur needs to be 3Amp for non-Pre-heater models and 16Amp for Pre-heater models.

Connecting a Boost (Light) Switch

A Switched Live LS may be used to boost the airflow when a light is turned on, for instance in a bathroom or kitchen. (The unit can be switched to boost by applying 220-240V to the LS input).

If the LS core of the mains cable is not used it should be terminated in an appropriate manner.

The LS connection should only be used if the switch live is on the same circuit as the unit.

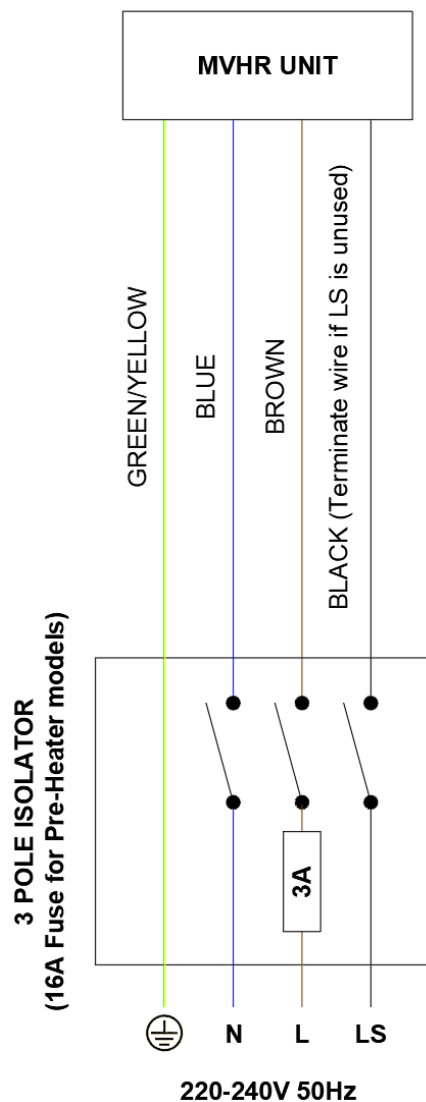

Accessing the Main PCBA



WARNING

ENSURE THE ELECTRICAL SUPPLY AND CONTROLS ARE ISOLATED FROM THE MAINS POWER SUPPLY BEFORE REMOVING ACCESS COVERS

Step 1: Remove the front cover by pressing the tabs either side of the control module and lifting the cover outwards from the bottom edge.

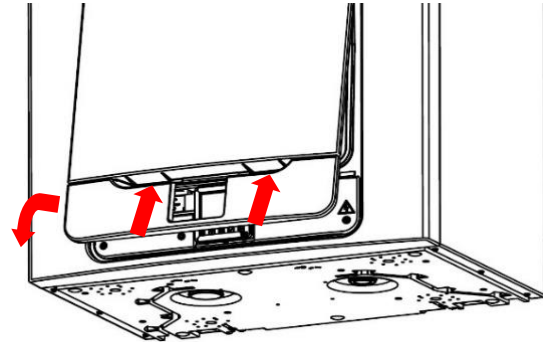

Step 2: Remove the two screws on either side of the access panel. Lift the panel outwards from the bottom edge to remove.

Note: The access panel is tethered on the left-hand side.

Note: All printed circuit boards are ESD sensitive. Always ensure the correct ESD protection is used.

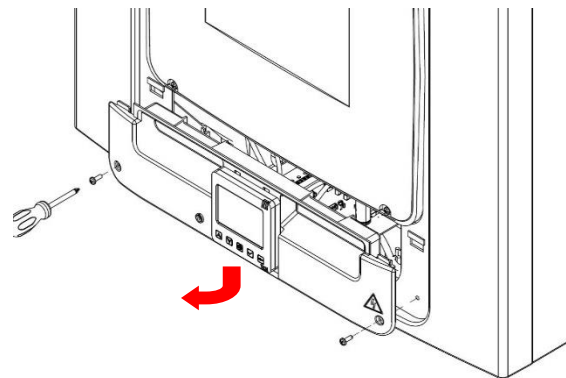

Step 3: Push the locking tab away from the printed circuit board and slide it outwards to access the terminals.

Note: The printed circuit board will relock after 60mm.

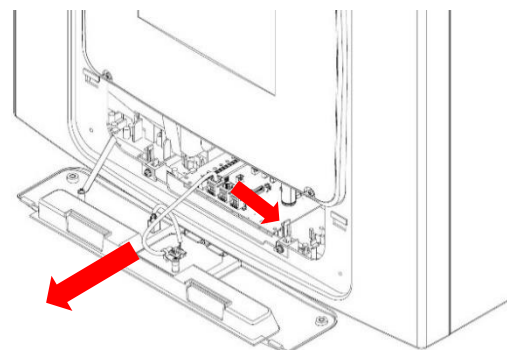

Connecting a Boost (Light) Switch from a different circuit, Controllers and Sensors

For good EMC engineering practice, any sensor, switched live or Volt free cables should not be installed within 50mm of other cable or on the same metal cable tray as other cables.

When fitting external controls, all cables should be routed through the back of the unit shown below.

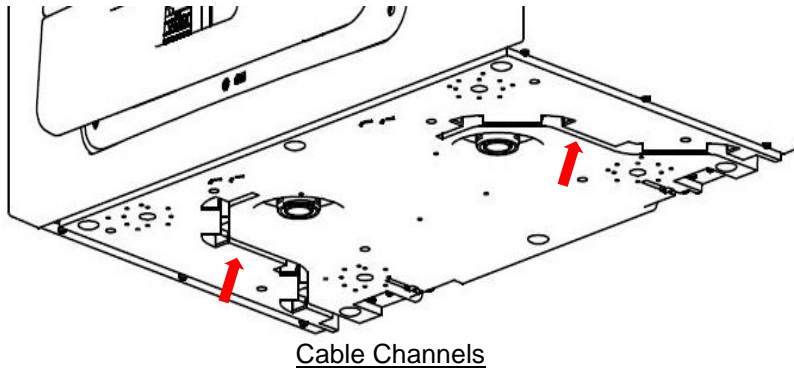

Connect any switches or sensors required to the unit via the terminal connections along the side of the main PCB, as shown below.

If necessary, contact your distributor regarding the wiring and fixing of accessories and sensors.

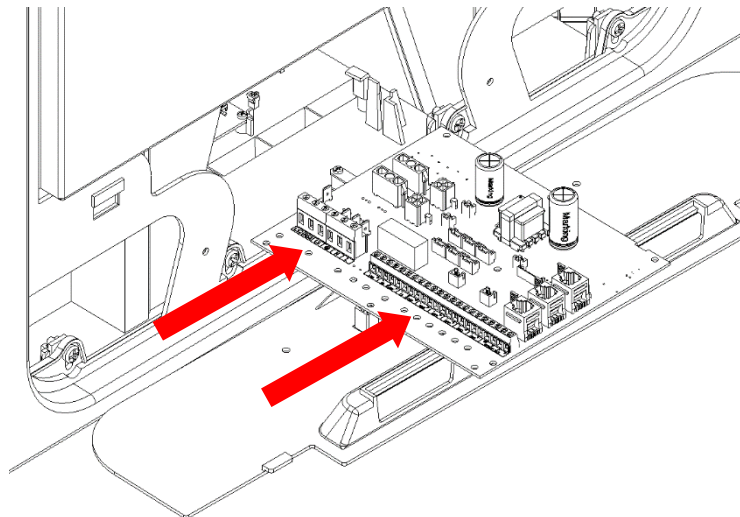

Terminal Connections

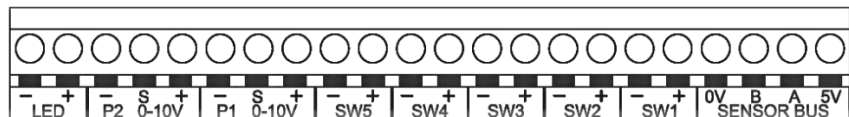

Terminal No.	Name	Description
LS2	Switched Live 2	220-240 V AC, 50 Hz input
NS2	Switched Neutral 2	220-240 V AC, 50 Hz input
LS	Switch Live	Switch Live (Common neutral with Mains Supply)
⊕ EARTH	Mains Earth	Earth connector
N	Mains Neutral	220-240 V AC, 50 Hz input
L	Mains Live	220-240 V AC, 50 Hz input
LED	Red Light Emitting Diode Output	A LED driving signal output between the - and + terminals that enables remote indication of a unit fault. See the Control Panel for fault code (see on page 33). May also be used for a connection to a BMS or similar.
P2 -s+ P1 -s+	0-10V	0-10V sensor input with 24V supply terminal
SW 1-5	Switch 1 to 5	Volt-free contact for sensor input between - and + terminals
0V, B, A, 5V	Sensor Bus	RS485 Termination for remote wired sensors/Controller

Connecting a Boost (Light) Switch from a different circuit

If the supply used for the Switched Live is on a different circuit to the power connections, the connections LS2 and NS2 should be used, via a separate isolator.

Please follow circuit diagram as shown.

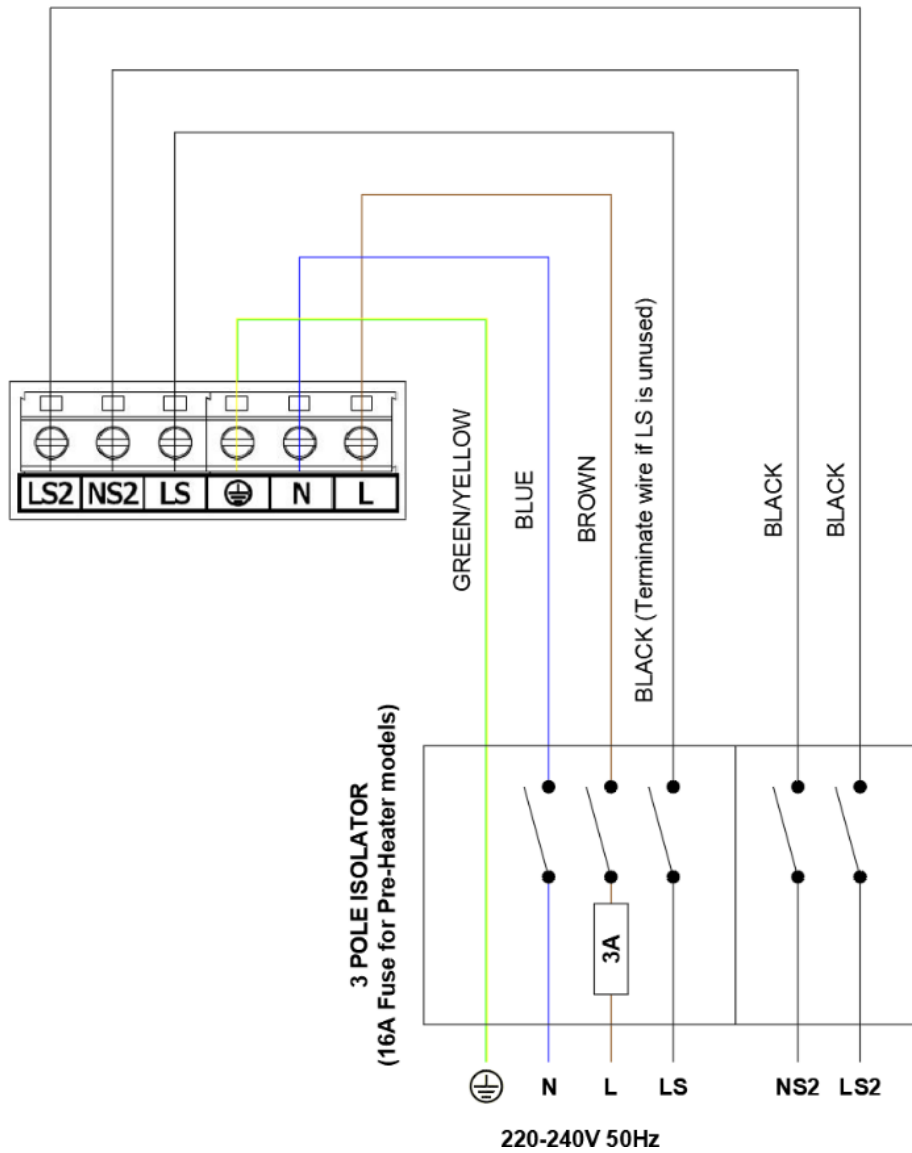

Powering up the Unit

Switching On

To switch the unit on:

1. Switch on the power at the mains supply isolator feeding the unit.
2. Following switch-on, after initialisation (up to 2 minutes) the fan motors will start and the Control Unit will display the home screen.

N.B. If you are intending to carry out work or maintenance inside the unit, isolate the supply to the unit before removing any covers.

Switching Off

To switch the unit off:

1. Turn the power off at the mains supply isolator.

Initialisation/Loading Screen



The image shows a control unit screen during its initialisation phase. The screen displays '99999999' at the top, a percentage sign followed by '55', and four right-pointing chevrons. Below the screen are five physical buttons: up, down, menu, confirm, and a plus sign. Arrows point from text labels to the screen and the plus button.

Firmware version
1 – HMI
2 – Bluetooth & WiFi
3 – PCB Main Board

The Initialisation can take 2 minutes to complete.

Primary Devices
Idle White LED indicates primary HMI, this device supports Bluetooth/Wifi connection (see Smart Device Pairing)

Additional Devices (If purchased)
Idle Green LED indicates secondary HMI device, no Bluetooth/WiFi support. (Refer to Pairing Sensors)

Serial number on initialisation

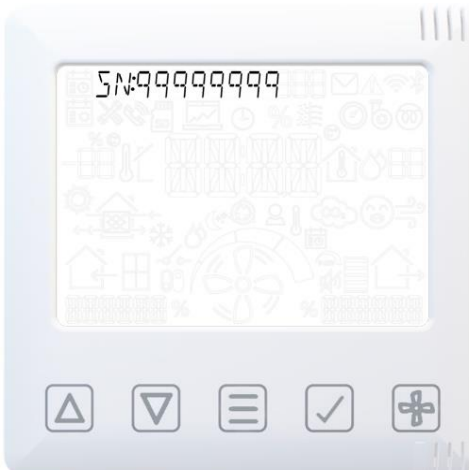

The image shows the control unit screen after initialisation is complete. The screen displays 'SN:99999999' at the top. The background of the screen is filled with various icons representing different system components. Below the screen are the same five physical buttons as in the previous image.

Serial number displayed after initialisation is complete.

Overview

The instructions in this section are intended to provide configuration and operation information for setting up the equipment. In the event of problems, see Diagnosing a Problem on page 33.

Follow good practice when commissioning the unit. Ensure that the system is installed according to the system designer's intent incorporating any acoustic ducting, that all joints are airtight, ducting is well supported, bends are avoided close to vents, and that the vent valves are fully open at the start of the commissioning process.

Commissioning of the unit should be done via the App. See page 19 for Smart Device Pairing.

Display overview – Home screen

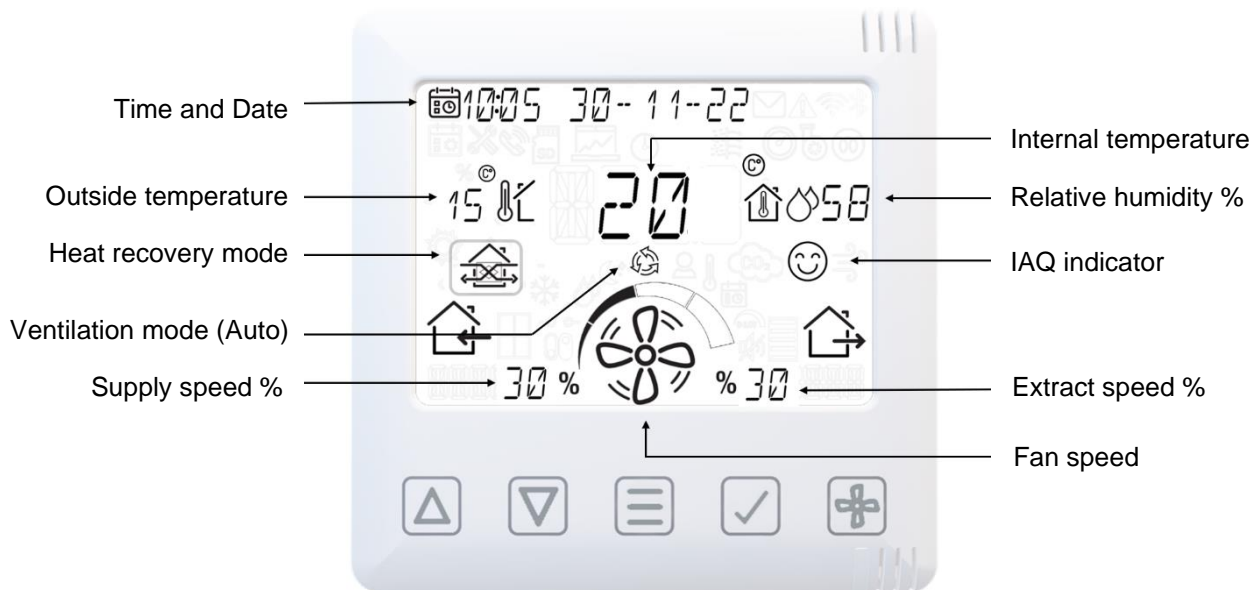

Home User Menu

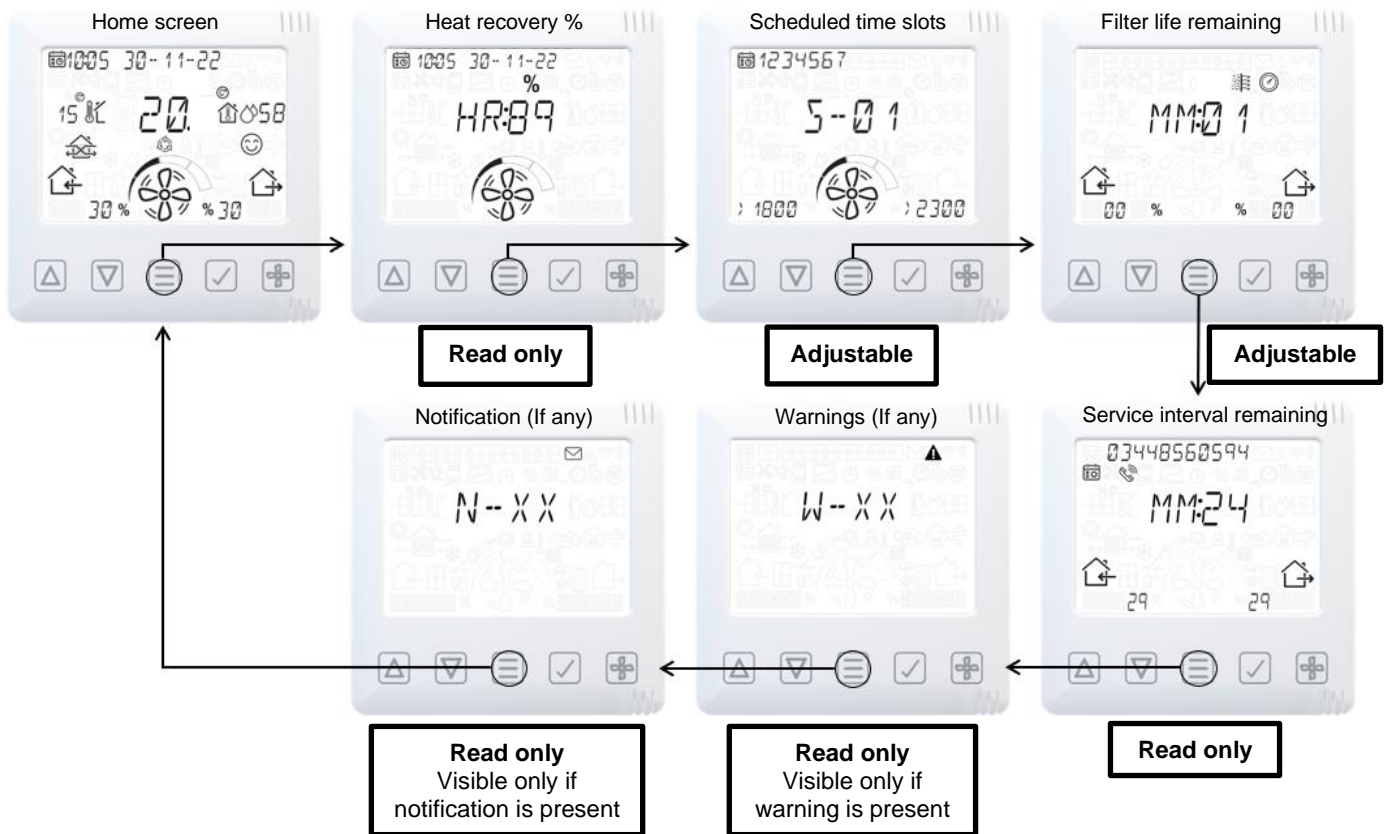

Display overview – Additional icons



Display overview – Mode indicators



Display overview – Indoor air quality monitor

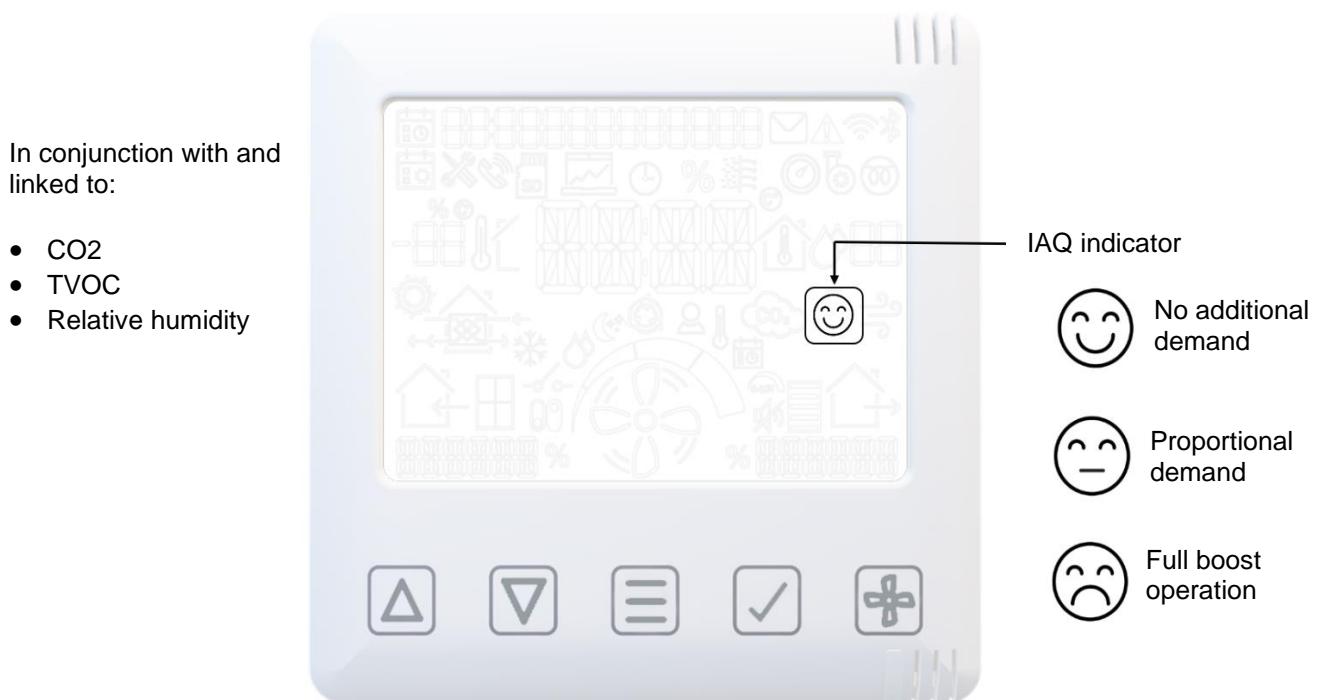

Display overview – Heat Recovery mode

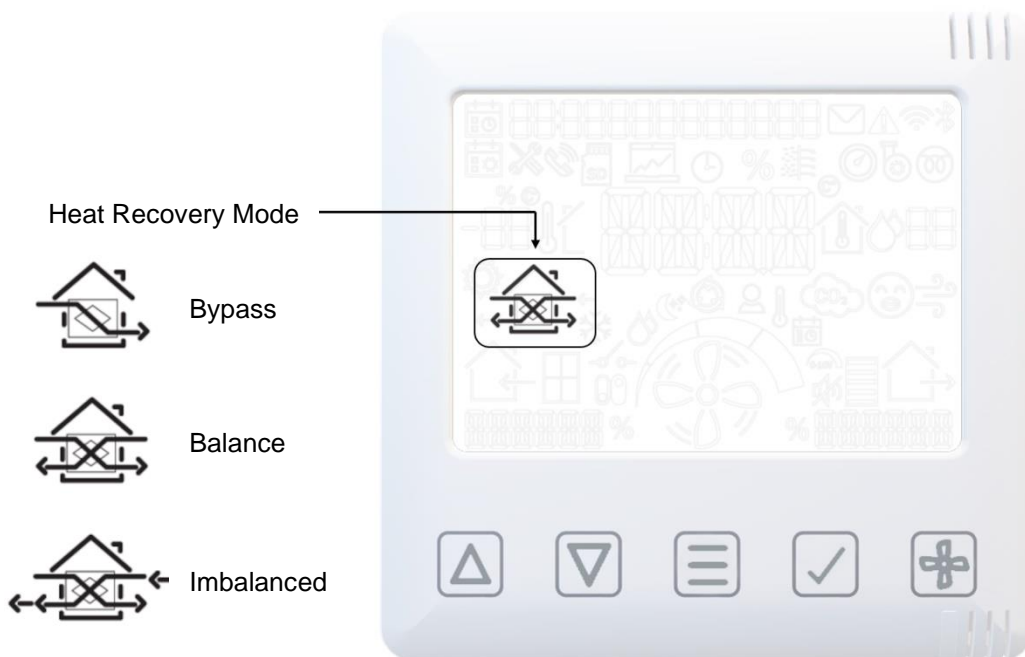

Smartphone Device Pairing and App download

To be utilized in conjunction with App Instructions

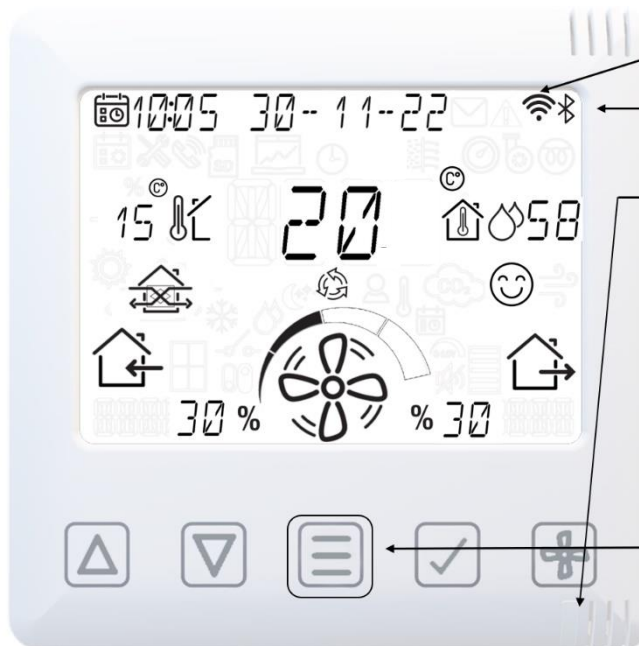





The App allows the user instant access to commissioning, configuration, direct monitoring and control of the MVHR unit, using a smart phone or tablet with the **Vent-Axia Connect App**, available from the iTunes Store or on Google Play.







Pairing sensors

To pair the unit with a wired or wireless sensor:

- Press the **MENU**  button to turn on the display.
- Press and hold the **MENU**  button until the LED illuminates solid White.
- Release the **MENU**  button, the LED will flash White to indicate that it is in pairing mode. The unit will remain in pairing mode for 5 minutes, or until the **MENU**  button is pressed again.
- Activate the pairing function on the sensor to be paired (see the instructions that came with the sensor).
- When a sensor is paired the total number of paired devices is displayed on the unit (P-XX).

Removing sensors

To remove paired sensors, the unit must be reset. Caution, this will reset all values back to factory default.

- Press the **MENU**  button to turn on the display.
- Press and hold the **MENU**  button until the LED illuminates solid Red.
- Release the **MENU**  button, the LED will stay Red.
- Pressing the **MENU**  button again will confirm the reset command. If a reset is not wanted, leave the unit until the command times out and the LED turns off.

Speed override

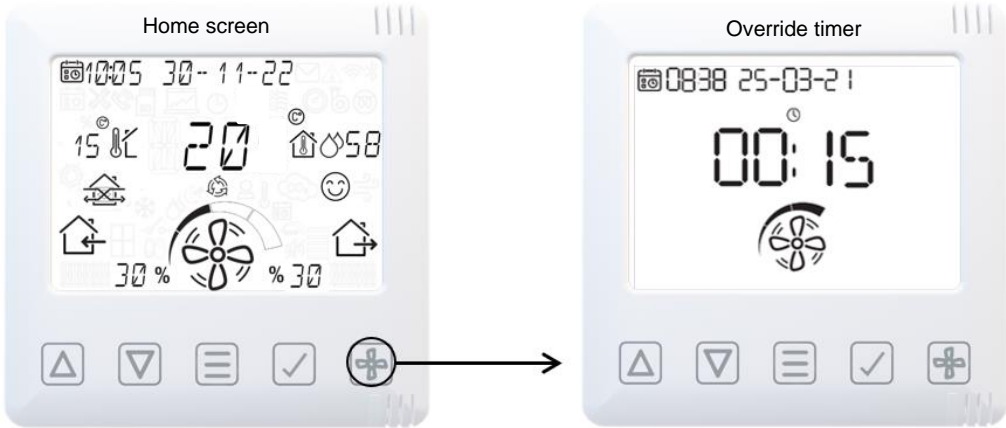

- Increase Timer
- Decrease Timer
- Change Fan Speed – Low, Normal, Boost, Purge
- Confirm Timer

Schedule

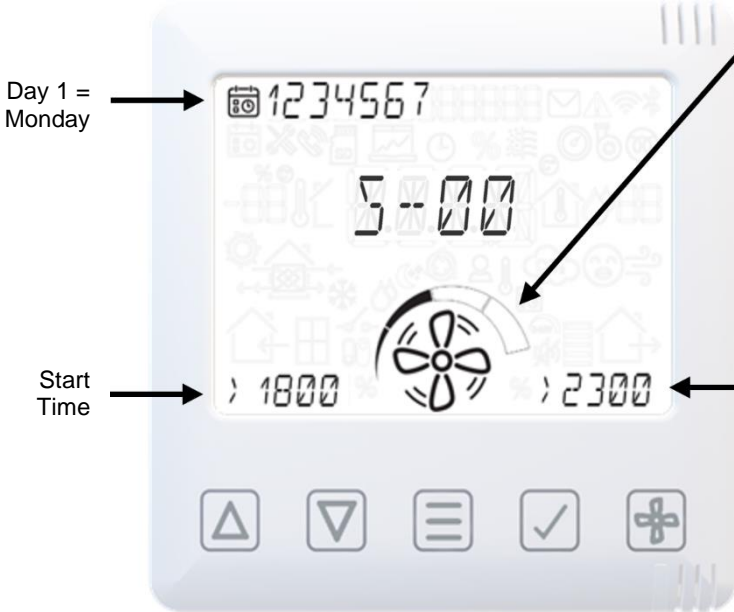



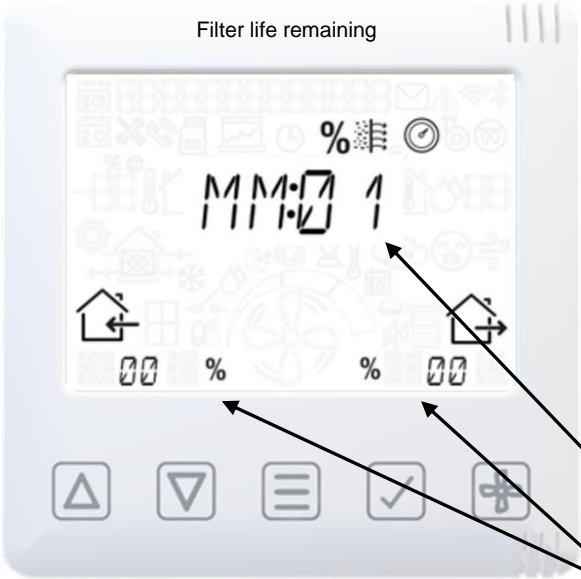

- Fan Speed
- 1 Bar = Low
 - 2 Bar = Normal
 - 3 Bar = Boost
 - 4 Bar = Purge

- Press 2 x from Home Screen to enter scheduling.
- Enter edit mode/Confirm Selection.
- Move between existing schedules and adjust schedule times/days in edit mode.
- Move between existing schedules and adjust schedule times/days in edit mode.
- Change Fan Speed – Low, Normal, Boost, Purge when flashing.

Filter reset



-  Press 3 x from Home Screen to enter filter screen.
-  Enter Reset/Confirm Selection.
-  Change service duration for filters: 3, 6 or 12 months.
- 
- Months remaining, will indicate when filters need replacing/cleaning.
- Models with filter pressure sensors fitted, filter life is indicated by % block values.

Warning Screen

Please see Page 33 for warning codes

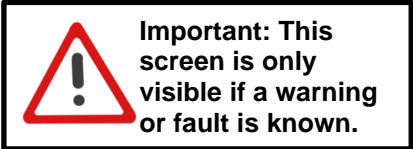

Service Interval Remaining

Month remaining before service is due.

Notifications if any



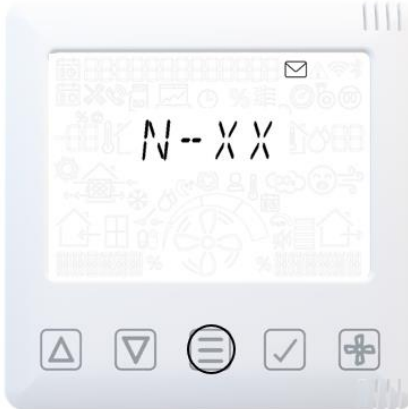
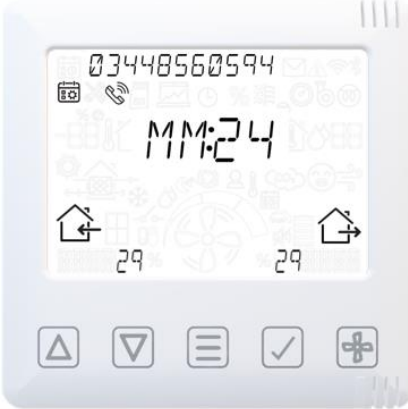

Please see Page 33 for warning codes



Engineer menu

Engineering mode



-  Press and hold for 3 seconds to exit or enter the Engineer Menu.
-  Use up and down to adjust each pin number and press  to confirm each number and enter Engineer settings.
- 

Engineer Overview

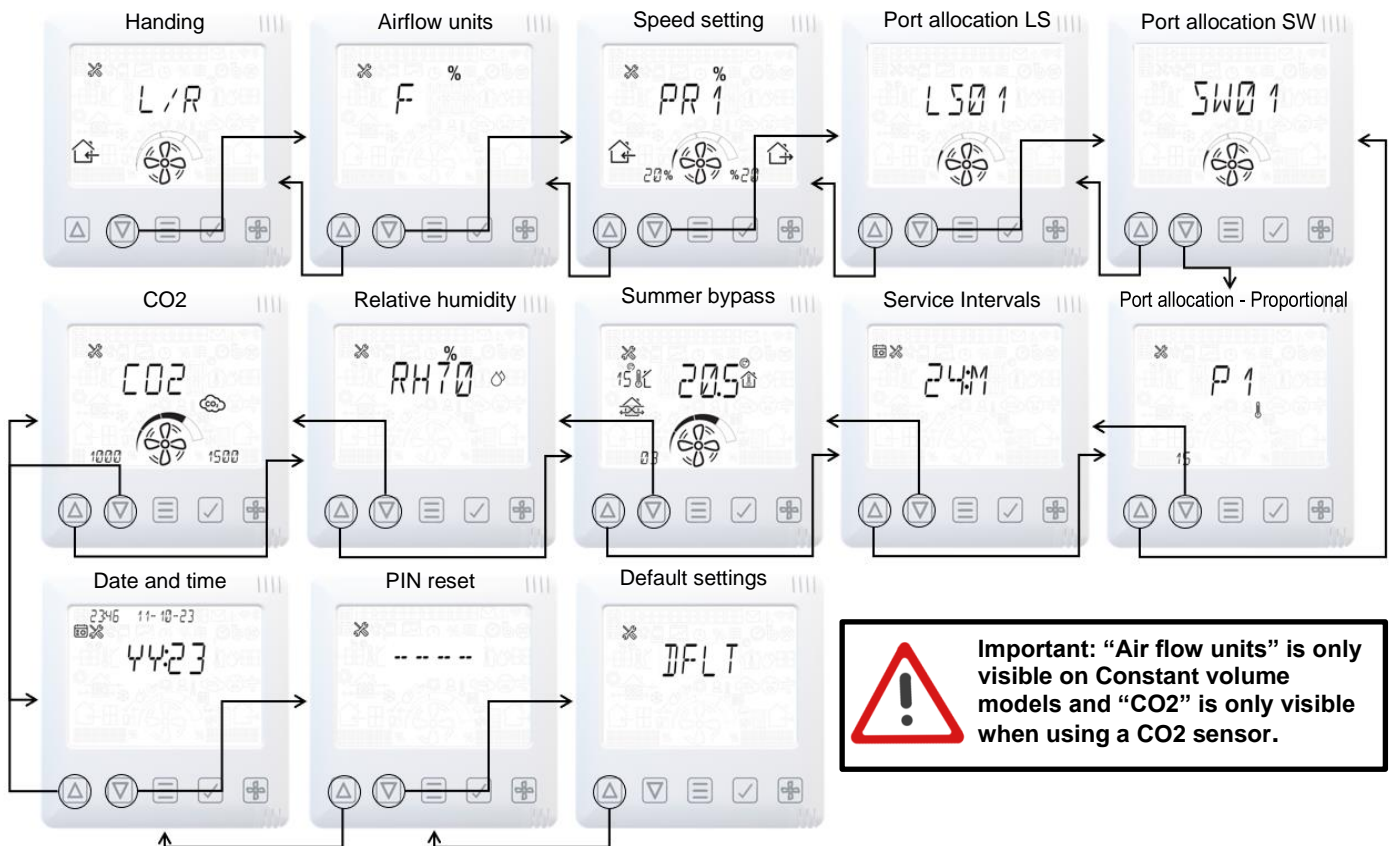

Engineer menu – Unit handing

Please see page 4 for details of handing.

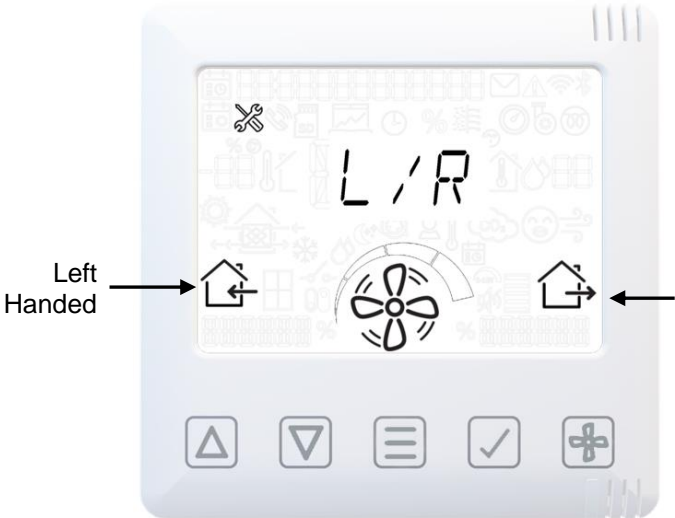

- Enter Menu/Confirm Selection
- Left Handed = L
- Right Handed = R

Engineer menu – Airflow units

User can select preferred airflow units.

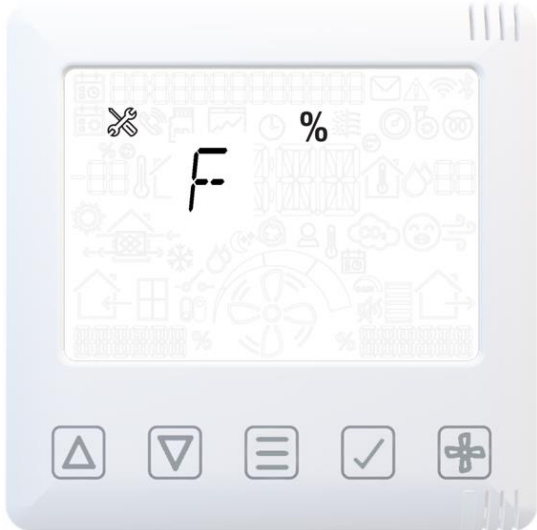





- Enter Menu/Confirm Selection
- Alternate measures
L/S M3/H C-F

This is only visible and used on Constant volume models.

Engineer menu – Airflow speed setting

% will be displayed as l/s for Constant volume models.



-  Select PR1-4
-  Enter/Confirm Selection
-  Adjust flow rate as % pr l/s
- 



- PR1 = Low Speed 20%**
Default
- PR2 = Normal Speed 30%**
Default
- PR3 = Boost Speed 50%**
Default
- PR4 = Purge Speed 100%**
Default



MVHR unit will run at speed indicated on this screen to aid commissioning.

Engineer menu – Port allocation LS



-  Change Fan Speed – Low, Normal, Boost, Purge
-  Enter/Confirm Selection
-  Change Port for Live Switch LS01 or LS02



Other switch modes are available when configured through the App.

Engineer menu – Port allocation SW



 Change Fan Speed – Low, Normal, Boost, Purge





 Enter/Confirm Selection

 Change Port Switch SW01 to SW05

Engineer menu – Proportional control



 Press Once for Zonal Selection

 Press twice for Control method Selection

 Change Proportional Control P1 or P2

 Change Zonal Control 1-15
or

 Control Method Temperature,
Humidity, 0-10V, CO2

Engineer menu – Service Intervals



Engineer menu – Summer bypass

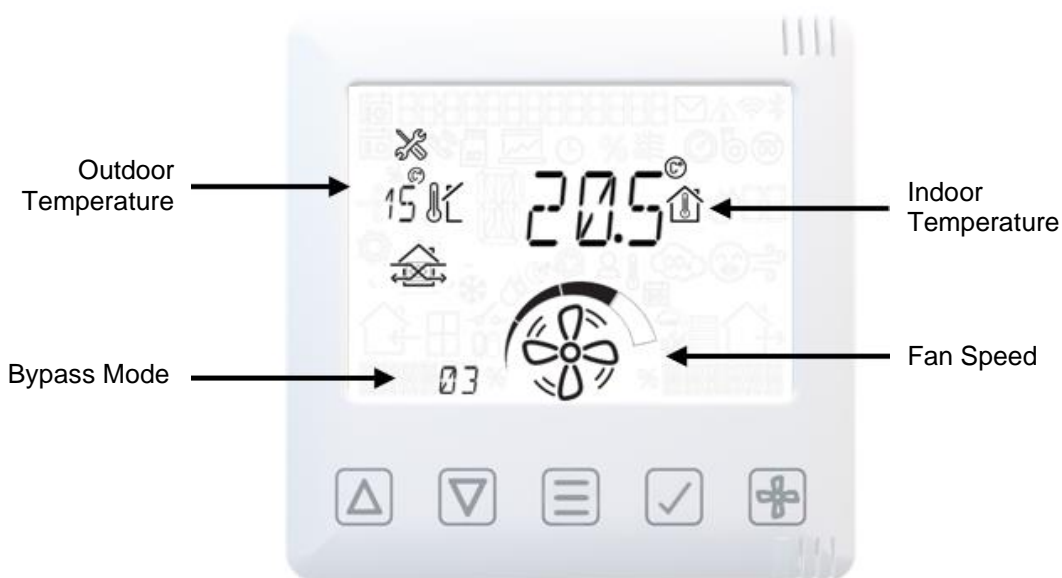

Press 1 x for Bypass Mode

00 = Disabled (not recommended)

01 = Normal Bypass

02 = Evening Fresh

03 = Night Time Fresh

See page 36 for details

Change Fan Speed - Low, Normal, Boost, Purge



Press 2 x for Indoor Temperature

Change field up/down

Press 3 x for Outdoor Temperature

Press 4 x for return to main menu

Engineer menu – Humidity





- Enter/Confirm Selection
- Change Relative Humidity between 50-90%
- 70% Default

Rapid rise can be Enabled/Disabled via the App. Along with Ambient response/overrun times.

Engineer menu – CO2 threshold

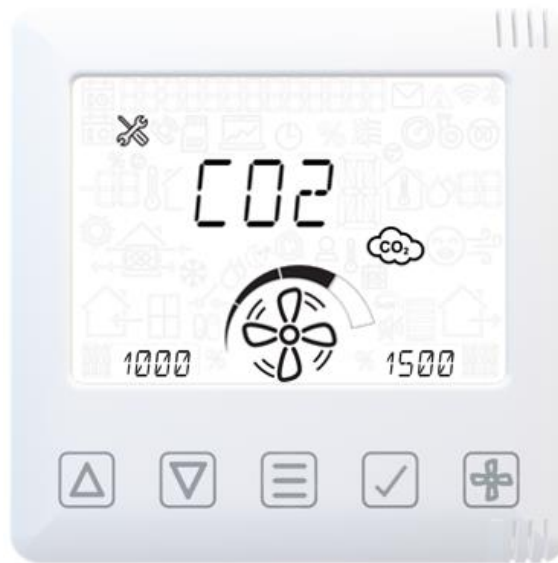
This is only visible when the CO2 sensor is installed.



- Enter/Confirm Selection
 - Change Fan Speed - low, normal, boost, purge
- 
- Change CO2 PPM Threshold 1000-2000 Default
 -

Engineer menu – Date / Time



Enter/Confirm Selection

Change entry within below field.

YY = Year
MM = Month
DD = Day
HH = Hour
MM = Minutes

Engineer menu – PIN Change



Enter/Confirm Selection

Change Pin Number 1-9

Engineer menu – Default settings



Push and hold the menu button for 15 seconds to reset to default including commission speeds.

LED will illuminate Red.

Press TICK to confirm Default Settings.

HMI - Hard reset

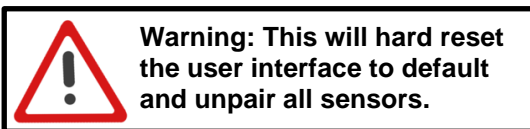

Push and hold the menu button for 15 seconds.

LED will illuminate Red.

Press TICK to confirm HMI reset.

OR

Press menu to confirm unit reset.

Filter Maintenance

Heat recovery units require regular maintenance. This unit has been designed to facilitate access to enable maintenance to be carried out easily.

When the unit displays a warning symbol and warning code: W-12 filter cleaning/replacement is overdue. When it displays notification N-1 the filter may need cleaning/replacement within the next month.

This is a reminder to ensure that the filters are not so dirty that they are blocking the airflow or allowing dirt to pass through. The rate at which the filters become dirty will vary hugely depending on the environment and the activity within the property. See page 32 for a list of spare filters.

1. Open the filter drawers by pressing the finger plate upwards and sliding the drawer out.
2. Lift each filter out and clean gently by tapping or carefully using a vacuum cleaner if necessary.

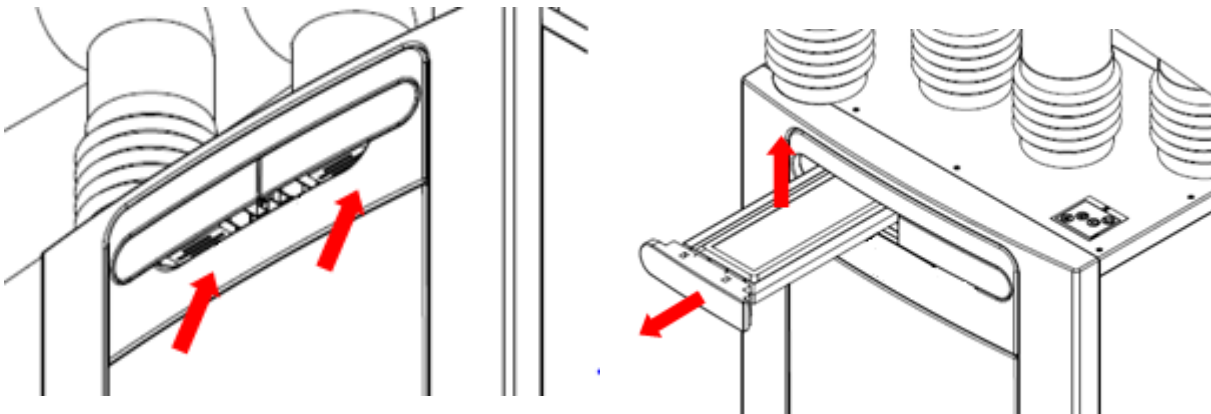

3. Replace the filters. (G4 as standard).
4. Close the filter drawers, ensuring the latches have clicked back into the locked position.
5. After maintenance of the filters, the filter timer can be reset via the controller (see page 21).

Periodic Maintenance



WARNING

THE FAN AND ANCILLARY CONTROL EQUIPMENT MUST BE ISOLATED FROM THE POWER SUPPLY DURING MAINTENANCE.

Heat Exchanger Cell

Step 1: Remove the outer cover by pressing the tabs either side of the control module and lifting the cover outwards from the bottom edge.

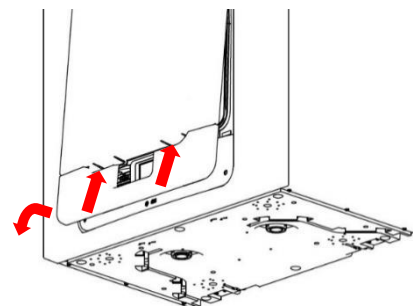

Step 2: Remove the inner door by undoing the 4 retaining screws.



Note: (When fitting inner door back to the unit, make sure the arrow is in the up position shown).

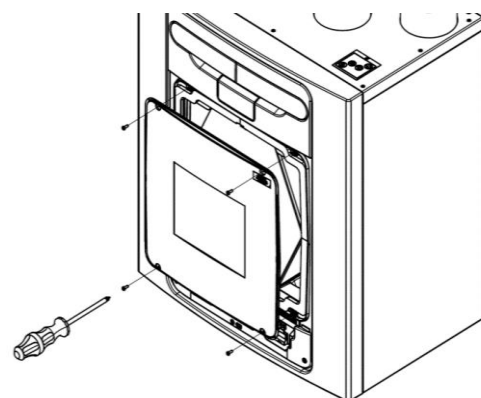

Step 3: Slide the heat exchanger out from the unit. (If cell is stiff to pull out of unit, pull cell strap from top, then from the bottom).



Warning: Sharp edges on cell ribs. Keep hands away from corners & wear gloves.

Step 4: Wash the outer cover and heat exchanger in warm water using a mild detergent (such as Milton Fluid) and dry thoroughly.



NOTE: Keep water away from all electrical components and wiring within the unit.

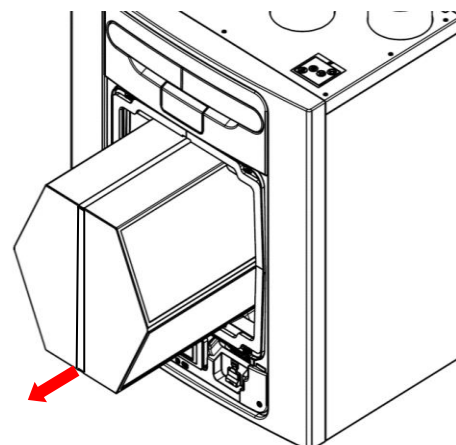

Motors

Inspect the motors for build-up of dust and dirt on the impeller blades, which could cause imbalance and increased noise levels. Vacuum or clean if necessary.

Condensate Drain

Check the condensate drain tube is secure and clear of debris. Clean if necessary. Ensure the trap is filled to the appropriate level of water if using a wet trap.

Fastenings

Check that all unit and wall-mount fastenings are sufficiently tight and have not become loose. Re-tighten if necessary.

Spares

The following spare parts may be ordered from Vent-Axia:

Part No	Description
??????	Main PCBA – Contact Technical Support
411622	Control Module (HMI with Display)
411703	Control Module (HMI with no Display)
472667	Filters G3, 2 per pack
477360	Filters G3, 50 per pack
411689	Filters G4, 2 per pack (Standard)
472669	Filters M5, 1 per pack
472671	Filters F7, 1 per pack
472673	Motor Scroll Assembly
472675	Summer Bypass Motor Assembly
411976	Temperature/Humidity Sensors T1 & T3 (Green & Yellow)
472679	Temperature Sensor T2 (Red)
472683	Temperature Sensor T4 (Brown)
411708	CO2/Temp Humidity Sensor T1 (Green)
411706	CO2/Temp Humidity Sensor T3 (Yellow)
476354	Wall Bracket
476356	Condensate Drain Cap & Screw

Diagnosing a Problem

In the event of a problem, always troubleshoot the unit according to:

- **Notification code** displayed on the control unit.
A notification flag indicates service/maintenance will be due soon.
- **Warning code** displayed on the control unit.
A warning code is advisory and will not immediately stop the function of the unit.
- **Fault code** displayed on the Control Unit.
The unit may have stopped functioning due to the fault.
- **Fault LED** if connected.

Service/Fault Codes

For assistance contact the service provider and quote the fault code number and the product serial number which can be found behind the front cover.

Note that the fault code is not displayed until the fault has been present for 3 minutes.

Fault Codes	
ID	Cause
F-1	Intake Thermistor
F-2	Extract Thermistor
F-3	Supply Fan
F-4	Extract Fan
...	
F-32	HMI Comms Lost

Warning Codes	
ID	Cause
W-1	Supply Temperature
W-2	Exhaust Temperature
W-3	Preheater Temperature
W-4	Intake RH
W-5	Extract RH
W-6	Supply Flow
W-7	Extract Flow
W-8	Filter Sensor 1
W-9	Filter Sensor 2
W-10	System Over-pressure
W-11	Preheater Tripped
W-12	Filter Clean Overdue
W-13	Service Overdue
W-14	Controller Device Lost
W-15	BMS Offline

Notification Codes	
ID	Cause
N-1	Intake Thermistor
N-2	Extract Thermistor

There may be new fault codes not listed here, please ensure that you always review the latest F&W available on our website under the product page and downloads.

Power on Self-Test

The LED blinks RED for 'X' times, based on the error bit flag that is set.
e.g. "Storage" 3x flash – Pause – 3x flash.....

MVHR (HMI)

Self-Test Failures	
Flash	HMI
1	RNG - Random Number Generator (RNG) peripheral has failed as part of self-test routine
2	Flash - DS-45DB081E flash chip initialisation failed
3	Storage – Error with Read/Write access to flash
4	HMI – Initialisation for UC1677LCD (LCD driver) failed
5	CapSense – Error with initialisation of CAP1298
6	SHT3x – Sensor Initialisation failed
7	ESP32 – No response the Sync event as part of self-test
8	RF868 – Core 2 not initialized, or Auto Tune has failed (Auto tune yet to be added)
9	Applnit- Error with respect to Initialisation of Application modules

MVHR (Mainboard)

Self-Test Failures	
Flash	Mainboard
1	RNG - Random Number Generator (RNG) peripheral has failed as part of self-test routine
2	RTC – RTC initialisation failed
3	<i>Eeprom(reserved) – not used for now</i>
4	Flash – DS-45DB081E flash chip initialisation failed
5	Storage – Error with Read/Write access to flash
6	External RAM – FM24V01A RAM Chip Initialisation failed
7	Ventilation Engine – Ventilation Engine not initialised
8	Applnit- Error with respect to Initialisation of Application modules
9	Modbus – Modbus intialisation failure

Accessories

Part No	Description
496429	Temp/RH Wired & Wireless RS485 & RF868
496431	Temp/RH Battery Powered
496433	CO2 +Temp & RH Wired & Wireless
496438	PIR Wired & Wireless
496437	SSU Speed Switch 4-WAY Battery, Wireless (White)
497689	SSU Speed Switch 4-WAY Battery, Wireless (Black)
496620	SSU Speed Switch 4-WAY Mains, Wireless (White)
497693	SSU Speed Switch 4-WAY Mains, Wireless (Black)
496621	SSU Speed Switch 4-WAY Mains, Wired (White)
497697	SSU Speed Switch 4-WAY Mains, Wired (Black)
411628	Wall-Mounting HMI Kit
448356	Remote LED indicator and lead

Flow Rate Settings

The Unit has four (4) user defined speeds, which are adjustable in the advance setting menu or via the App. The speed mode names are customisable via the App.

Default speed modes names: -

- Low
- Normal (Unit default operating mode)
- Boost
- Purge

Frost Protection

Frost Protection is required to prevent condensate freezing in the heat exchanger at low temperatures. The process is fully automatic. The method used for frost protection will depend on the model and building it is installed in.

For buildings with a leak rate of 3m³/hr or less (at 50Pa), a balanced frost protection mode must be used. A balanced mode must also be used when a combustion device without a dedicated air supply is present.

Airflow (Imbalanced)

Airflow mode reduces the Intake flow and increases the Extract flow in varying proportions dependent on the incoming air temperature. The unit will continue to recover heat as low as “-20°C”. At this point, the unit switches to 'Extract Only' mode.

Bypass (Balanced)

Bypass mode opens the Summer Bypass and stops recovering heat until the external temperature increases sufficiently.

Airflow & Preheater (Imbalanced)

If a preheater is fitted, the preheater will turn on to warm the incoming air to above freezing. If the air temperature is so low that the heater cannot warm the air sufficiently, the supply flow rate will be reduced to compensate.

Airflow & Preheater (Balanced)

If a preheater is fitted, the preheater will turn on to warm the incoming air to above freezing. If the air temperature is so low that the heater cannot warm the air sufficiently, both the supply and extract flow rate will be reduced to compensate.

Summer Bypass Mode

The MVHR includes an intelligent Summer Bypass (SBP) feature, this bypasses the heat exchanger when necessary to provide free cooling, this is triggered when the desired Indoor Temperature is above the ambient temperature.

Note that the volume of air provided by a ventilation system is a fraction of that required for space heating or space cooling and will not in itself be sufficient to cool a room. It will however provide a contribution.

Modes of operation

Bypass Mode	Operation
Off	Summer Bypass feature is disabled, Bypass will be active during Anti-frost
Normal	The unit will run on Normal Mode, unless cancelled
Evening Fresh	The unit will run on the user selected Mode for 5-hours before reverting to Normal, unless cancelled
Night-Time Fresh*	The unit will run at the user selected Mode, unless cancelled

Bypass mode will operate when both the Indoor and Outdoor temperature thresholds are exceeded, and the outdoor temperature is below the indoor temperature.

Indoor Temp: This is the maximum desired indoor temperature. Above the set indoor temperature, the summer bypass will operate.

Indoor temp should be set, 2-3°C higher than the central heating thermostat to prevent the bypass operating in winter, and 2-3°C lower than any air conditioning thermostat if fitted.

Outdoor Temp: This is the minimum allowed outdoor air temperature. The air temperature must be above this value for the Bypass to operate, use this value to prevent the bypass operating in winter.

The suggested Outdoor Temp, is 14°C, set as appropriate for your region.

Bypass mode will be cancelled when either:

- The internal air temperature drops below the Indoor Temp threshold, or
- The external air temperature drops below the Outdoor Temp threshold

It is recommended that the user selected mode chosen for Evening Fresh and Night-Time Fresh is higher than Normal flow rate to reduce the indoor temperature more rapidly.

*Night-Time Fresh Mode is intended for use through the night when cooling is a higher priority than any increase of noise. Note, that the air noise in your system is influenced by flowrate, ducting design, layout and the size and type of vents used in the rooms. If improvements are required, please contact your installer.

Product Dimensions

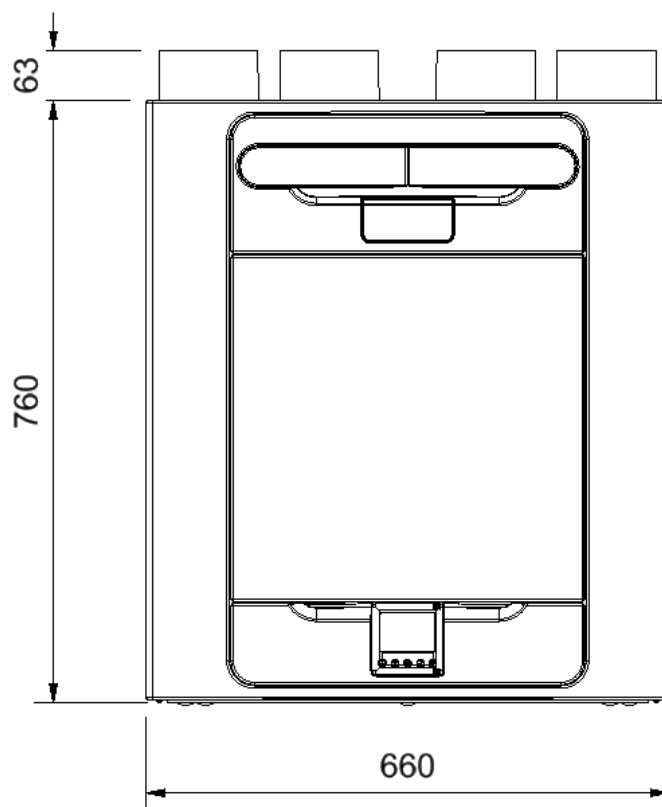
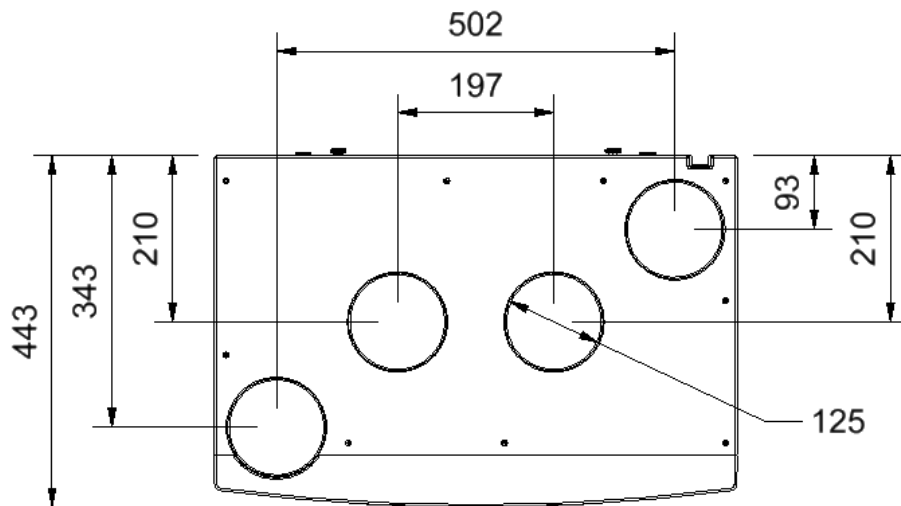

Remove front cover (see page 12) to view Rating label.
 (Label is positioned to the right of the controller).

Default Settings

Parameters	Settings
Commissioning Screens	
Country	United Kingdom
Date	Automatic - Factory set
Unit configuration	Right Hand
Filter Check	12 months
Summer Bypass	Normal
Mode Names	Normal, Boost, Low, Purge (Only in App)
User Mode	
Boost Supply/Extract	50 %
Normal Supply/ Extract	30 %
Low Supply/Extract	20%
Purge Supply/Extract	100%
Internal RH Mode	On
Internal RH Setpoint	70%
Control Mode	Normal
Frost Protection	Airflow Mode
Mode schedule 1	All days set to 0:00 (on), 00:00 (off) – inactive
Mode Schedule 2	All days set to 0:00 (on). 00:00 (off) – inactive
Service Phone	Not Set (Settable in App)
Set Lock code	0000
Indoor Temp	25 C
Outdoor Temp	14 C
Boost Over-run	Off
Boost Overrun set time	15
Boost Delay	Off (Only in App)
Boost Delay set time	00 (Only in App)
LS1/LS2	User Mode 3 (Boost)
SW1/SW2/SW3/SW4/SW5	User Mode 3 (Boost)
Proportional 1/2	Humidity – Boost, Normal (60 %) CO2 – Boost (2000 ppm), Normal (1000 ppm) Temperature – Boost (27°C, Normal (17°C)

Product Fiche

Name:	Vent-Axia
Model ID (Stock Ref.):	499883 - Sentinel Econiq S 411077 - Sentinel Econiq SC 499890 - Sentinel Econiq SCP RH 499891 - Sentinel Econiq SCP LH
SEC Class	A+
SEC Value ('Average')	-42.64
SEC Value ('Warm')	-17.27
SEC Value ('Cold')	-87.72
Label Required? (Yes/No=Out of scope)	Yes
Declared as: RVU or NRVU/UVU or BVU	RVU/UVU
Speed Drive	Variable Speed
Type HRS (Recuperative, Regenerative, None)	Recuperative
Thermal Eff: [(%), NA (if none)]	91
Max. Flow Rate (m3/h)	350
Max. Power Input (W): (@Max.Flow Rate)	166
LWA: Sound Power Level (dB)	48.5
Ref. Flow Rate (m3/s)	0.068
Ref. Pressure Diff. (Pa)	50
SPI [W/(m3/h)]	0.31
Control Factor & Control Typology: (CTRL/ Typology)	
Control Factor; CTRL	0.65
Control Typology	Local Demand Control
Declared: -Max Internal & External Leakage Rates (%) for BVUs or carry over (for regenerative heat exchangers only), -&Ext. Leakage Rates (%) for Ducted UVUs;	<5% Internal, <5% External
Mixing Rate of Non-Ducted BVUs not intended to be equipped with one duct connection on either supply or extract air side;	N/A
Position and description of visual filter warning for RVUs intended for use with filters, including text pointing out the importance of regular filter changes for performance and energy efficiency of the unit	Refer to User Instructions
For UVUs (Instructions Install Regulated Supply/Extract Grilles Façade)	N/A
Internet Address (for Disassembly Instructions)	www.vent-axia.com
Sensitivity p. Variation@+20/-20 Pa: (for Non-Ducted VUs)	N/A
Air Tightness-ID/OD-(m3/h) (for Non-Ducted VUs)	N/A
Annual Electricity Consumption: AEC (kWh/a)	2.07
Annual Electricity Consumption: AEC (kWh/a) Per. 100m ²	207
Annual Heating Saved: AHS (kWh/a)	
AHS: Average	47.14
AHS: Warm	21.32
AHS: Cold	92.22

CE00537

Vent-Axia

Vent-Axia

Fleming Way, Crawley,
West Sussex RH10 9YX

T: +44 (0) 844 856 0580

F: +44 (0) 1293 551188

W: www.vent-axia.com

**UK
CA**

UK DECLARATION OF CONFORMITY

Reference Number: CE00537

Issue: A 1023

Product Name(s)/Description:



Sentinel Econiq S Range

Model Name(s)	Part Number(s)
Sentinel Econiq S	499883
Sentinel Econiq Se (Export)	412465
Sentinel Econiq SC	411077
Sentinel Econiq SCP RH	499890
Sentinel Econiq SCP LH	499891

Following the provisions of Directives & Regulations as appropriate.

Electrical Equipment (Safety) Regulations 2016: Great Britain	<input checked="" type="checkbox"/>
Electrical Equipment (Safety) Regulations 2016: Northern Ireland	<input checked="" type="checkbox"/>
Electromagnetic Compatibility Regulations 2016	<input checked="" type="checkbox"/>
RoHS Regulations 2019	<input checked="" type="checkbox"/>
WEEE Waste electrical and electronic equipment Regulations 2013	<input checked="" type="checkbox"/>
REACH UK Registration, Evaluation, Authorisation and restriction of Chemicals Regulation	<input checked="" type="checkbox"/>
Ecodesign requirements for ventilation units (EU) regulation No 1253/2014 Implementing Directive 2009/125/EC	<input checked="" type="checkbox"/>
Radio Equipment Regulations 2017	<input checked="" type="checkbox"/>

Standards Applied - Radio	Standards Applied - Safety	Standards Applied - EMC
BS EN 300 328 V2.1.1 & V2.2.2	BS EN60335-1:2012 + A11:2014	BS EN55014-1:2006+A2:2011
BS EN 300 220 V2.4.1	BS EN60335-2-80:2003+A2:2009	BS EN55014-2:1997+A2:2008
BS EN 301 489 V1.9.2 In accordance with BS EN 301 489-17 V2.2.1		



 Lee Austin, Group Technical Director (Crawley, UK)

12/10/23

.....
Date

CE00537



Vent-Axia
 Fleming Way, Crawley,
 West Sussex RH10 9YX
 T: +44 (0) 844 856 0580
 F: +44 (0) 1293 551188
 W: www.vent-axia.com



EU DECLARATION OF CONFORMITY

Reference Number: CE00537

Issue: A 1023

Product Name(s)/Description:

Sentinel Econiq S Range

Model Name(s)	Part Number(s)
Sentinel Econiq S	499883
Sentinel Econiq Se (Export)	412465
Sentinel Econiq SC	411077
Sentinel Econiq SCP RH	499890
Sentinel Econiq SCP LH	499891

Following the provisions of Directives & Regulations as appropriate.

Low Voltage Directive (2014/35/EU)	<input checked="" type="checkbox"/>
Electromagnetic Compatibility Directive (2014/30/EU)	<input checked="" type="checkbox"/>
RoHS use of hazardous substances Directive (2017/2102/EU)	<input checked="" type="checkbox"/>
WEEE Waste electrical and electronic equipment Directive (2012/19/EU)	<input checked="" type="checkbox"/>
REACH Registration, Evaluation, Authorisation and restriction of Chemicals Regulation (EC 1907/2006)	<input checked="" type="checkbox"/>
Ecodesign requirements for ventilation units (EU) regulation No 1253/2014 Implementing Directive 2009/125/EC	<input checked="" type="checkbox"/>
Radio Equipment Directive (RED) (2014/53/EU)	<input checked="" type="checkbox"/>

Standards Applied - Radio	Standards Applied - Safety	Standards Applied - EMC
EN 300 328 V2.1.1 & V2.2.2	EN60335-1:2012 + A11:2014	EN55014-1:2006+A2:2011
EN 300 220 V2.4.1	EN60335-2-80:2003+A2:2009	EN55014-2:1997+A2:2008
EN 301 489 V1.9.2 In accordance with EN 301 489-17 V2.2.1		

.....
 Lee Austin, Group Technical Director (Crawley, UK)

12/10/23

.....
 Date

EU Authorised Representative: Vent-Axia Sigarenmaker 5 - 5521DJ Eersel Nederland authorisedrep@vent-axia.nl

Evolution Ventilation UK Limited (Co No: 11352032) Trading as Vent-Axia. Registered office: Fleming Way, Crawley, West Sussex RH10 9YX.

Disposal



This product should not be disposed of with household waste. Please recycle where facilities exist. Check with your local authority for recycling advice.

The **Vent-Axia** Guarantee

Applicable only to products installed and used in the United Kingdom. For details of guarantee outside the United Kingdom contact your local supplier.

Vent-Axia guarantees its products for two years from date of purchase against faulty material or workmanship. In the event of any part being found to be defective, the product will be repaired, or at the Company's option replaced, without charge, provided that the product: -

- Has been installed and used in accordance with the instructions given with each unit.
- Has not been connected to an unsuitable electricity supply. (The correct electricity supply voltage is shown on the product rating label attached to the unit).
- Has not been subjected to misuse, neglect or damage.
- Has not been modified or repaired by any person not authorised by the company.

IF CLAIMING UNDER TERMS OF GUARANTEE

Please return the complete product, carriage paid to your original supplier or nearest Vent-Axia Centre, by post or personal visit. Please ensure that it is adequately packed and accompanied by a letter clearly marked "Guarantee Claim" stating the nature of the fault and providing evidence of date and source of purchase.

The guarantee is offered to you as an extra benefit and does not affect your legal rights.

Vent-Axia.

Head Office: Fleming Way, Crawley, West Sussex, RH10 9YX

EU Authorised Representative: Vent-Axia Sigarenmaker 5 - 5521DJ Eersel Nederland authorisedrep@vent-axia.nl

UK NATIONAL CALL CENTRE: -

Sales Enquiries: Tel: 0344 8560590

Email: sales@vent-axia.com

Technical Support: Tel: 0344 8560594

Email: vatechsupport@vent-axia.com