

Sentinel

Kinetic MVHR Range

Installer & Homeowner Guide



Stock Ref. N°

- 438222 Kinetic B Right
- 438222L Kinetic B Left
- 443319 Kinetic BH Right
- 443319L Kinetic BH Left
- 408167 Kinetic FH Right
- 408169 Kinetic FH Left
- 443028 Kinetic Plus B Right
- 443028L Kinetic Plus B Left
- 408449 Kinetic High Flow Right
- 408451 Kinetic High Flow Left

For replacement filters
 goto:- <https://www.vent-axia.com/findyourfilter>

Or scan the QR Code below to guide you to the Vent-Axia filter pages

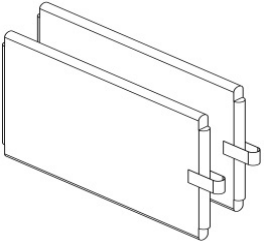
Filter check record:- Select interval Required Installer to tick as appropriate.

Note:- This is dependent on the environment in which the unit is installed.

Urban 6 Months	Suburban 9 Months	Rural 12 Months

Please fill in commissioned motor speeds in the table below:-

	Extract	Supply	
Boost	%	%	
Normal	%	%	

Please add the date of the next required filter change below:-



DOWNLOAD INSTALLATION & USER GUIDE BY SCANNING THE QR CODE.
 OR GOTO:- <https://www.vent-axia.com/residential-systems-manuals>

INSTALLATION MUST BE CARRIED OUT BY SUITABLY TRAINED AND QUALIFIED PERSONS.

THE INSTRUCTIONS MUST BE READ BEFORE STARTING UP THE UNIT AND SHOULD BE KEPT WITHIN REACH OF THE INSTALLATION AND SERVICE TECHNICIAN.



PLEASE LEAVE THESE INSTRUCTIONS WITH THE END USER OR WITH THE PRODUCT.

Information for the installer - Warning & Safety Information

- Do not install this product in areas where the following may be present or occur:
 - Excessive oil or a grease laden atmosphere.
 - Corrosive or flammable gases, liquids or vapours.
 - Subject to direct water spray from hoses.
 - Ambient temperatures higher than 40°C and lower than -20°C.
 - Possible obstructions that may hinder access to or removal of the unit.
- All wiring must be in accordance with the current IEE wiring regulations BS7671, or appropriate standards of your country. Installation should be inspected and tested by a suitably qualified person after completion.
- Ensure the mains supply (voltage, frequency and phase) complies with the rating label.
- To allow disconnection of the supply after installation the unit should be provided with a local double pole fused spur fitted with a 3A fuse having a contact separation of at least 3mm. If a unit fitted with a preheater is being installed, a 13A fuse should be used.
- Precautions must be taken to avoid the back-flow of gases into the building from the open flue of gas or other fuel-burning appliances. External grilles should be positioned in accordance with your local building regulations, however as a minimum we recommend that the inlet grille is kept 2m from any discharge grille or flue outlet.
- This appliance is not intended for use by persons (including children) with reduced physical, sensory or mental capabilities, or lack of experience and knowledge, unless they have been given supervision or instruction concerning use of the appliance by a person responsible for their safety.
- Young children should be supervised to ensure that they do not play with the appliance.
- The installer is responsible for the installation and electrical connection of the sentinel system on site. It is the responsibility of the installer to ensure that the equipment is safely and securely installed and left only when mechanically and electrically safe.
- All regulations and requirements must be strictly followed to prevent hazards to life and property, both during and after installation, and during any subsequent servicing and maintenance.
- The unit's condensate drain must be connected to the building's wastewater drainage system.
- Certain applications may require the installation of sound attenuation to achieve the sound levels required.
- The unit must not be connected directly to a tumble drier.
- The supply and exhaust valves must be fully opened prior to commissioning.
- The intake air must be drawn from the exterior of the property.
- The unit should be allowed to stabilise during commissioning for a minimum period of 5 minutes when changing between boost and normal speeds.
- This product and associated duct installation should be carried out in accordance with the Domestic Ventilation Compliance Guide.
- Before carrying out maintenance ensure the fan is switched off from the mains before removing covers.
- Caution:- In order to avoid hazard due to inadvertent re-setting of the thermal cut-out, this appliance must not be supplied through an external switching device such as a timer or connected to a circuit that is regularly switched off by the utility.
- In the event of failure please contact your local supplier.

Information for the home owner

Home Owners Ventilation System Guide

(For the Home owner once the installation is complete)

Sentinel Kinetic Range Pre-Set Ventilation System

DO NOT...

...Switch off the unit

- The unit is set to run continuously 24 hours a day, 7 days a week.

...Adjust the ceiling grilles

- These grilles are set to allow a certain amount of air through and should not be adjusted.

What is it and why is it there?

A centralised fan unit mounted in your loft space or cupboard that draws stale moist air and odours from your bathroom, kitchen, WC and removes it from the property through the circular grilles mounted in your ceiling.

What does it do?

It continuously moves air around your property at such a low level that you never feel it, but it takes all the stale air from inside your house and replaces it with clean fresh air, 24 hours a day, 7 days a week.

Your home is ventilated without the need to open windows which can let in noise, fumes and can compromise security.

How will it help?

It will prevent the build-up of moisture in the house, remove steam/ condensation and odours during bathing and cooking, prevent black mould forming on the walls, behind cupboards etc. It will also help stop the dampness that you can get in your cupboards and wardrobes, on your clothes and furnishings, caused by poor ventilation.

How do I control it?

The Sentinel Kinetic operates continuously on 'Normal' setting to ensure your home is ventilated at the appropriate level.

The system will automatically boost to a higher extract rate when one of the control devices is activated.

A manual 'Boost' switch is also provided if a higher level of ventilation is required at any other time, e.g. on a hot day or to remove odours.

Maintenance

Filters should be cleaned when indicated by the unit control panel at varying intervals depending on external environment. Product should be professionally serviced annually. (See front cover for Filter interval requirement, and replacement filters).

Before Installation of the Unit (Information for the installer)

Inspect the Unit

When taking delivery of the unit, check the items delivered against the enclosed delivery note. Inspect the unit for damage in transit. If in doubt, contact Customer Services. Each box contains a Kinetic HR unit and an accessory pack containing wall bracket, condensate drain link pipe, pipe clips and product documentation.

Lift and Move the Unit Safely

Check the weight of the unit that you are installing. (See table below) Always use appropriate lifting techniques and appliances when moving heavy equipment.

Check Site Requirements and Safety Notices

Check that the physical and environmental conditions for the site meet, or exceed, the requirements detailed in the downloadable installation, operation and maintenance instructions.

Read and observe the safety notices listed in *Warnings and Safety Information* on page 2

Information for the installer

Connection & Dimension Diagrams

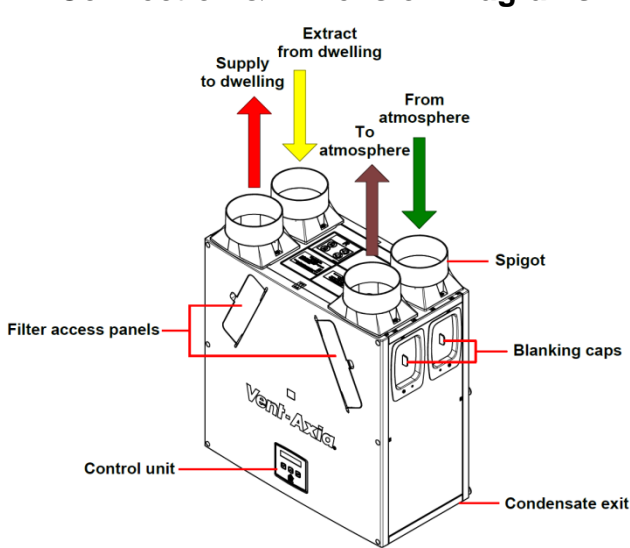

RH Right handed version Kinetic B /BH

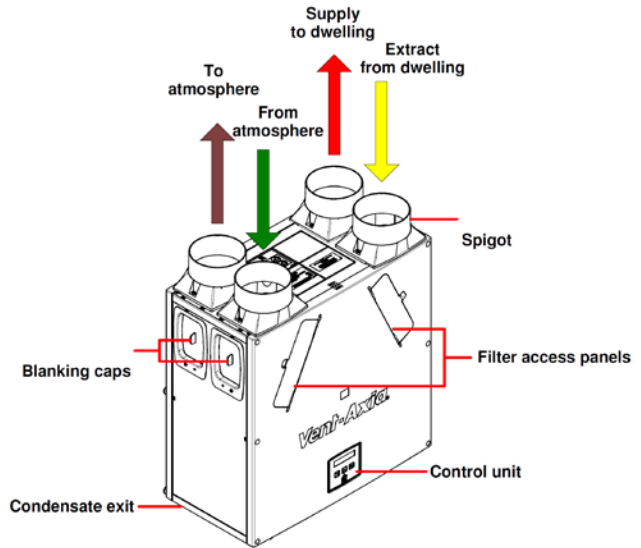

LH Left handed version Kinetic B /BH

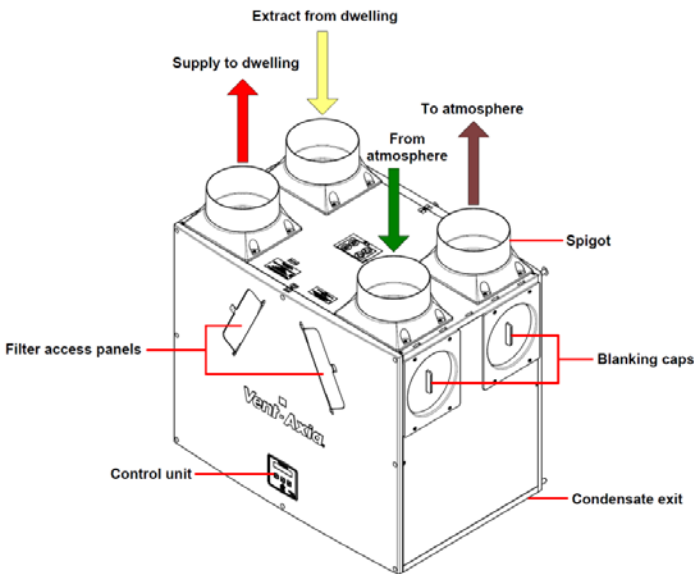

RH Right handed version Kinetic F, Plus & High Flow

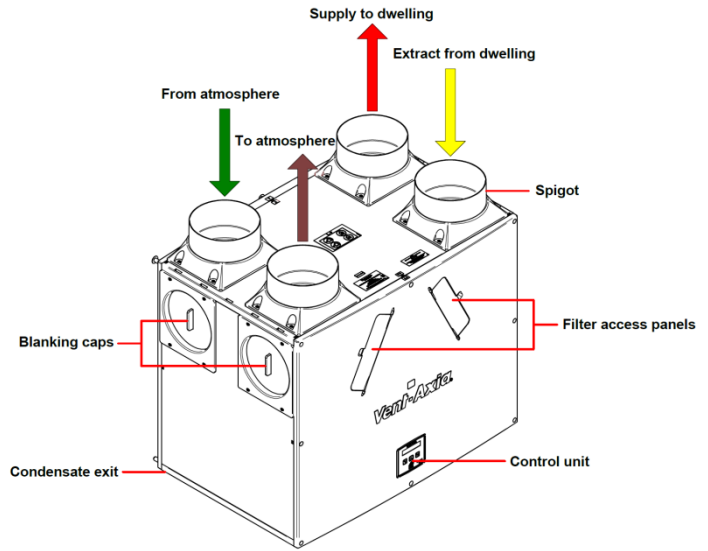

LH Left handed version Kinetic F, Plus & High Flow

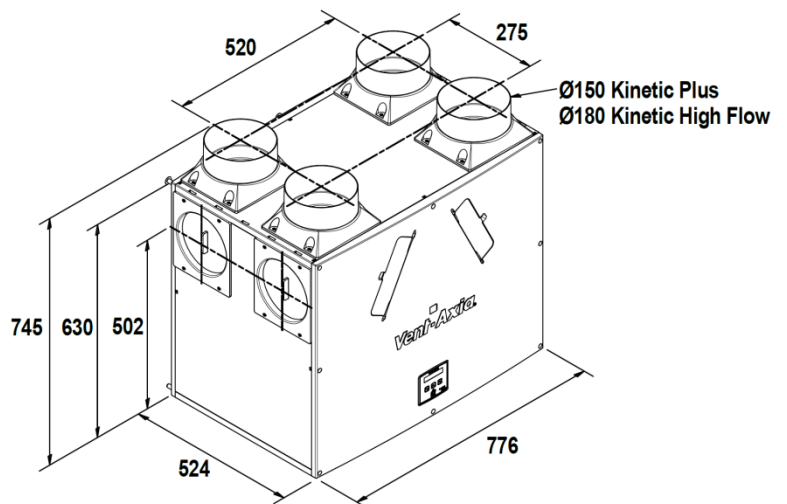
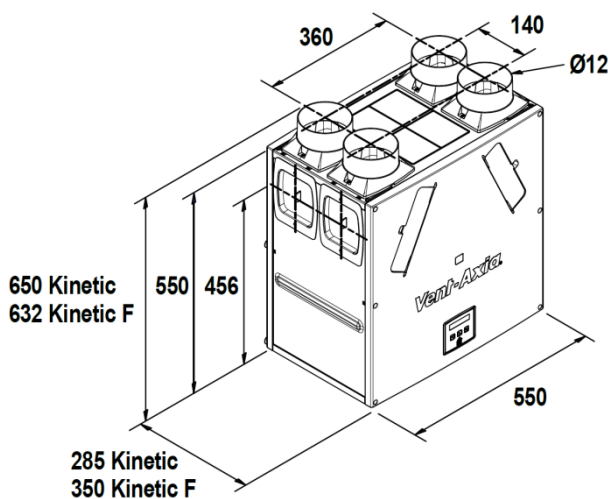

INFORMATION FOR THE INSTALLER

ACCESS AREA DIMENSIONS & WEIGHTS				
DIMENSIONS	KINETIC	KINETIC F	KINETIC PLUS	KINETIC HIGH FLOW
A (mm)	300	360	540	540
B (mm)	560	560	780	780
WEIGHT (kg)	15	19	24	38

The wall should have sufficient strength to support the unit. Take into consideration the position of the electrical services and the condensate drain. Ensure there is adequate access for installation, operation and maintenance. The unit **MUST** always be mounted vertically with ducting exiting vertically or horizontally. Do not use this unit as a support for any other equipment.

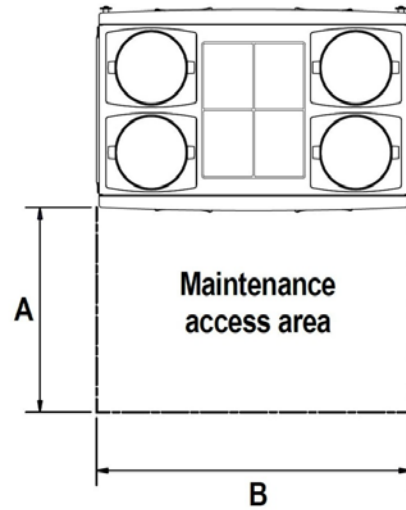

Wall Mounting

1. Refit the front and rear covers if they have been removed.
2. Ensure the two steel wall bushes are fitted to the rear cover, along the top row of screws.
3. Mark the condensate and wall bracket positions.
4. Fit the stand-off feet in place, supplied in the accessory bag
5. Fit metal wall bracket (supplied) to the wall using appropriate fixings.
6. Lift unit and locate the steel wall bushes onto the wall bracket. The unit should now be physically installed in its intended operating location.
7. Ensure that the condensate drain is connected.

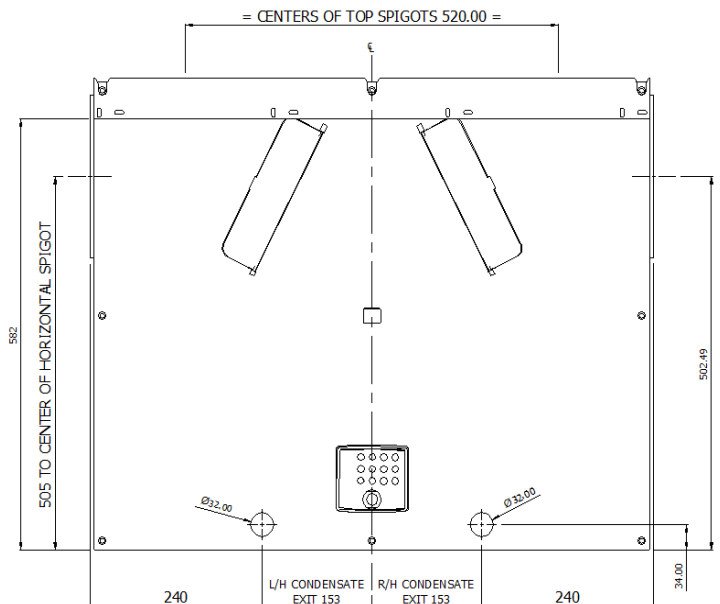
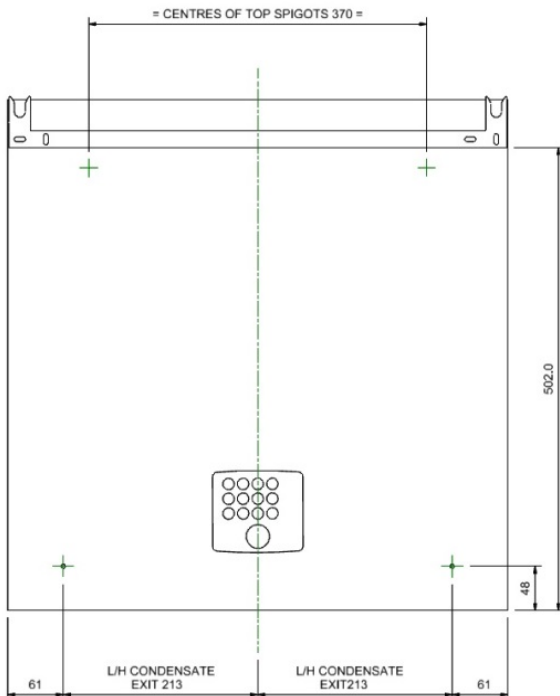
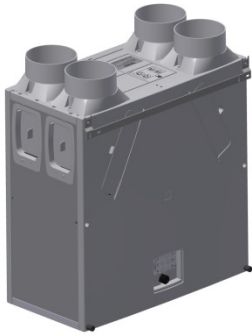

Drain connections

The condensate pipe should be attached with a worm drive clip to a 22 mm vertical pipe.



Fit a 'U' bend condensate drain having a minimum of a 60mm water seal or a HepVo valve to the building's foul water drainage system and ensure there is a minimum 3 degree fall to allow condensate drainage.

Always insulate condensate pipe if installing in a cold void.

Full details on the various condensation drain options are given in the installation, operation and maintenance instructions that **MUST** be downloaded from:- <https://www.vent-axia.com/residential-systems-manuals>

Electrical connections

Electrical wiring diagrams are given in the installation, operation and maintenance instructions that **MUST** be downloaded from:- <https://www.vent-axia.com/residential-systems-manuals>



1. MAINS SUPPLY VOLTAGES (220-240 V AC) ARE PRESENT IN THIS EQUIPMENT WHICH MAY CAUSE DEATH OR SERIOUS INJURY BY ELECTRIC SHOCK. ONLY A QUALIFIED ELECTRICIAN OR INSTALLER SHOULD CONNECT THE POWER SUPPLY TO THIS UNIT.
2. THIS UNIT MUST BE CORRECTLY EARTHED.
3. TO ALLOW DISCONNECTION OF THE SUPPLY AFTER INSTALLATION. THE INSTALLATION IS TO INCLUDE A SWITCH IN THE FIXED WIRING IN ACCORDANCE WITH THE WIRING REGULATIONS.

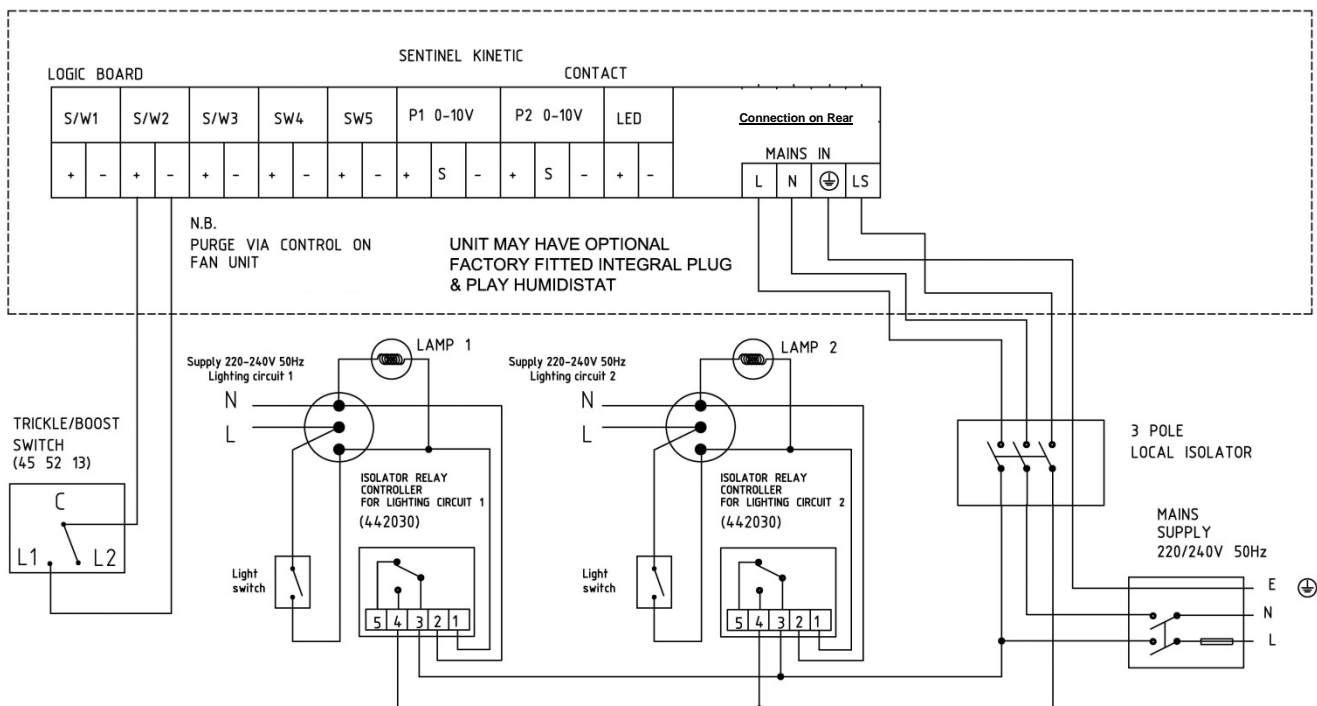

Connect switches and sensors

The unit can be switched to boost by a variety of methods:-

Applying 240V to the LS input.

Switching across 1 of 5 pairs of switch terminals (S/W1-5)

Applying between 0 and 10V as a proportional input to two input terminals (P1,P2)

PRODUCT FICHE

For Residential Ventilation Units (Complying Commission Delegated Regulation (EU) No 1254/2014)

Name:	Vent-Axia	Vent-Axia	Vent-Axia	Vent-Axia
Model ID (Stock Ref.) :	Kinetic B - 438222/L Kinetic BH – 443319/L	Kinetic FH 408167 / L 408169	Kinetic Plus B 443028/L	Kinetic High Flow 408449 / L 408451
SEC Class	A	A+	A+	A
SEC Value ('Average')	-41.41	-42.51	-43.81	-40.98
SEC Value ('Warm')	-16.49	-17.25	-18.55	-15.72
SEC Value ('Cold')	-85.69	-87.39	-88.70	-85.86
Label Required? (Yes/No=Out of scope)	Yes	Yes	Yes	Yes
Declared as: RVU or NRVU/UVU or BVU	RVU/BVU	RVU/BVU	RVU/BVU	RVU/BVU
Speed Drive	Variable Speed	Variable Speed	Variable Speed	Variable Speed
Type HRS (Recuperative, Regenerative, None)	Recuperative	Recuperative	Recuperative	Recuperative
Thermal Eff: [(%), NA(if none)]	87.00	90	90.00	90.00
Max. Flow Rate (m3/h)	237.60	331.2	432.00	666.00
Max. Power Input (W): (@Max.Flow Rate)	128.00	168	173.00	360.00
LWA: Sound Power Level (dB)	52.13	61.03	52.23	61.03
Ref. Flow Rate (m3/s)	0.04620	0.064	0.08400	0.12950
Ref. Pressure Diff. (Pa)	50.00	50	50.00	50.00
SPI [W/(m3/h)]	0.34	0.30	0.20	0.42
Control Factor & Control Typology: (CTRL/ Typology)				
Control Factor; CTRL	0.65	0.65	0.65	0.65
Control Typology	Local Demand Control	Local Demand Control	Local Demand Control	Local Demand Control
Declared: -Max Internal & External Leakage Rates(%) for BVUs or carry over (for regenerative heat exchangers only), -&Ext. Leakage Rates (%) for Ducted UVUs;	<5% Internal, <5% External	<5% Internal, <5% External	<5% Internal, <5% External	<5% Internal, <5% External
Mixing Rate of Non-Ducted BVUs not intended to be equipped with one duct connection on either supply or extract air side;	N/A	N/A	N/A	N/A
Position and description of visual filter warning for RVUs intended for use with filters, including text pointing out the importance of regular filter changes for performance and energy efficiency of the unit	Refer to User Instructions	Refer to User Instructions	Refer to User Instructions	Refer to User Instructions
For UVUs (Instructions Install Regulated Supply/Extract Grilles Façade)	N/A	N/A	N/A	N/A
Internet Address (for Disassembly Instructions)	www.vent-axia.com	www.vent-axia.com	www.vent-axia.com	www.vent-axia.com
Sensitivity p. Variation@+20/-20 Pa: (for Non-Ducted VUs)	N./A	N/A	N./A	N/A
Air Tightness-ID/OD-(m3/h) (for Non-Ducted VUs)	N./A	N/A	N./A	N/A
Annual Electricity Consumption: AEC (kWh/a) Per. 100m ²	2.23	2.04	1.52	2.65
Annual Heating Saved: AHS (kWh/a) Per. 100m ²				
AHS: Average	46.31	46.93	46.93	46.93
AHS: Warm	20.94	21.22	21.22	21.22
AHS: Cold	90.60	91.82	91.82	91.82

Installation good practice:-

1. Is any flexible ducting pulled taut to prevent moisture collection and avoids airflow issues?
2. Are all joints in the ductwork sealed to prevent air leakage?
3. Is the ducting insulated to prevent condensation and cooling or heating of the air?
4. Does the condensate drain
 - a) have the correct slope to ensure water runs away and
 - b) is fitted with a trap to prevent smells coming back into unit?

See the Installation Guide and Checklist at:

https://www.vent-axia.com/sites/default/files/domestic_ventilation_compliance_guide_2010_0.pdf

The **Vent-Axia** Guarantee

Applicable only to products installed and used in the United Kingdom. For details of guarantee outside the United Kingdom contact your local supplier.

Vent-Axia guarantees its products for two years from date of purchase against faulty material or workmanship. In the event of any part being found to be defective, the product will be repaired, or at the Company's option replaced, without charge, provided that the product:-

- Has been installed and used in accordance with the instructions given with each unit.
- Has not been connected to an unsuitable electricity supply. (The correct electricity supply voltage is shown on the product rating label attached to the unit).
- Has not been subjected to misuse, neglect or damage.
- Has not been modified or repaired by any person not authorised by the company.

IF CLAIMING UNDER TERMS OF GUARANTEE

Please return the complete product, carriage paid to your original supplier or nearest Vent-Axia Centre, by post or personal visit. Please ensure that it is adequately packed and accompanied by a letter clearly marked "Guarantee Claim" stating the nature of the fault and providing evidence of date and source of purchase.

The guarantee is offered to you as an extra benefit, and does not effect your legal rights

Disposal



This product should not be disposed of with household waste. Please recycle where facilities exist. Check with your local authority for recycling advice.

Vent-Axia

Head Office: Fleming Way, Crawley, West Sussex, RH10 9YX.

UK NATIONAL CALL CENTRE, Newton Road, Crawley, West Sussex, RH10 9JA

SALES ENQUIRIES: Tel: 0344 856 0590

TECHNICAL SUPPORT Tel: 0344 856 0594

For details of the warranty and returns procedure please refer to www.vent-axia.com
or write to Vent-Axia Group, Fleming Way, Crawley, RH10 9YX