

**Sabre Short Case Sickle Fans (VSC)
Sabre Sickle Plate Fans (VSP)**

**Euroseries Short Cased Axial Fans (ESC)
Euroseries Axial Plate Fans (ESP)**

Installation and Wiring Instructions



Vent-Axia[®]

PLEASE READ ALL INSTRUCTIONS CAREFULLY BEFORE STARTING INSTALLATION.
THESE INSTRUCTIONS SHOULD BE LEFT WITH THE END USER.

L-BAL-001-Vent-Axia-GB

2023/38 Index 003

Part-No.00295572

ROOF UNITS
from Vent-Axia

**UK
CA** **CE**

READ AND SAVE THESE INSTRUCTIONS

PLEASE READ ALL INSTRUCTIONS CAREFULLY BEFORE STARTING INSTALLATION. INSTALLATION AND WIRING INSTRUCTIONS SHOULD BE LEFT WITH END USER.

Compliance with the following instructions is mandatory to ensure the functionality and safety of the product. If the following instructions given especially but not limited for general safety, transport, storage, mounting, operating conditions, start-up, maintenance, repair, cleaning and disposal /recycling are not observed, the product may not operate safely and may cause a hazard to the life and limb of users and third parties.

Deviations from the following requirements may therefore lead both to the loss of the statutory material defect liability rights and to the liability of the buyer for the product that has become unsafe due to the deviation from the specifications.

Air moving equipment may present mechanical, electrical or noise hazards. To minimize risks associated with these potential hazards, it is essential that safety, installation, operation and maintenance instructions are followed. Implementation of these instructions should always be undertaken by technically competent personnel.

Potential mechanical hazards must be eliminated by guarding against access to the rotating parts whilst the air moving equipment is operating. A range of guards are available for this purpose from Vent-Axia.

Installation work, both mechanical and electrical, must be undertaken in accordance with the safety and installation instructions before switching on the unit.

Maintenance work should not be attempted before first switching off and isolating the fan and its control from the electrical supply and ensuring that it cannot be accidentally turned back on again. It is essential to ensure that rotating parts have come completely to rest before maintenance work commences.

Air moving equipment may generate unacceptable noise levels when in operation. It may be necessary to take appropriate action to reduce sound levels. A range of products are available for this purpose from Vent-Axia.

If the motor/fan is used in applications where a ignitable atmosphere can form in the event of a fault, e.g. due to leakage, the user must assess the risks of ignition and take appropriate precautions to prevent ignition.

IMPORTANT

1. All electrical connections should be made by a properly qualified electrician. The fan must be sited and connected in accordance with current IEE Wiring Regulations, BS7671 (U.K.), or the appropriate standards in your country.
2. DO NOT use this appliance when the following are generated or present: Excessive grease or oil laden air, corrosive or flammable atmospheres.
3. When the fan is installed in a room containing a fuel burning appliance, the installer must ensure that the air replacement is adequate for both the fan and the fuel burning appliance.
4. If a fan is used to supply air into a room, the installer must ensure that the fan intake is located at least 600mm away from any flue outlet.
5. Site away from direct sources of heat, ambient temperature range -40°C to +70°C.
6. When installing unit, take care not to damage electrical or other hidden utilities.
7. Check the details on the rating label for correct voltage, frequency, speed, phase insulation class and IP rating.
8. Select the correct direction of rotation for the fan.
9. It is the responsibility of the installer to ensure that all aspects of system design are taken into consideration.
10. Due to the weight of larger units it is recommended that two people are involved in the installation.
11. Warning: - Parts of the rotor or the entire rotor coming loose in case of a fault (e.g. excessive vibrations) can result in personal injury and material damage. Use guard grilles or suitable design measures for critical applications (e.g. refrigerating systems with refrigerant subject to the ordinance on hazardous substances).

FAN MOUNTING

CASED AXIAL FANS

1. A duct mounted in-line fan. Short duct runs terminating close to the fan (i.e. within 1.5m) require suitable guards.
2. The fan can be mounted in a variety of ways and at any angle to suit the application.
3. Plan the installation carefully, taking into consideration the safety points noted above, before securely fixing the fan using appropriate screws, bolts, rubber bushes, etc.
4. A range of accessories are available from Vent-Axia to assist installation including coupling flanges, flexible connectors, mounting feet, anti-vibration mounts and a wire inlet guard.

FORM OF RUNNING

Cased fans have arrows showing the direction of impeller rotation and airflow.

For reverse running the unit can be turned through 180°.

Alternatively, the airflow direction may be reversed by changing over the electrical connections in the fan, but a drop in performance will result.

PANEL MOUNTED AXIAL

1. The fan is designed to be positioned in a panel or wall aperture.
2. The fan is suitable for mounting at any angle using the corner holes.
3. Ensure the fan impeller rotates freely before and after installation.
4. Plan the installation carefully, taking into consideration the safety points noted above, before securely fixing the fan using appropriate screws, bolts, rubber bushes, etc.
5. If the fan is mounted less than 2.3m high, an external guard must be fitted. A range of Discharge Guards or Louvre Shutters are available from the Vent-Axia accessory list.

FORM OF RUNNING

Panel mounted fans (ex-stock) are supplied for extract use (Form 'A' running). When used for intake, the fan can be wired for reverse running, although performance will be reduced.

GENERAL WIRING INSTRUCTIONS

WARNING – THE FAN AND ANY ANCILLARY CONTROL EQUIPMENT MUST BE ISOLATED FROM THE POWER SUPPLY DURING INSTALLATION AND/OR MAINTENANCE. THE EQUIPMENT MUST BE EARTHED.

1. All electrical connections should be made by a properly qualified electrician.
2. All wiring and connections must be carried out in accordance with current regulations.
3. It is recommended that an all pole isolator switch is fitted adjacent to the fan for safety during maintenance/servicing.
4. Remove the cover from the terminal box to expose the main terminal block and the thermal protection block (TB). The thermal protection device fitted is an automatic resetting type which must always be included in the circuit. For ducted applications a manual reset is required, an ancillary circuit will be required with the TB switch connected into the circuit.
5. Connect the power supply from the local isolator (via any appropriate controls if fitted) to the terminal box via an appropriate cable gland. Refer to the wiring diagrams and select the appropriate connections for the fan, controller or other devices as being installed. If in doubt please ask.
6. Ensure that all earth connections have been made.
7. After making connections inside the terminal box, replace the cover ensuring that the sealing gasket is in place. Also ensure that all cable gland nuts, grommets etc. have been used correctly to prevent the ingress of water.

NOTES ON RUNNING

Before Connecting the power supply and running the Fan Check...

Are all links and wiring complete as per wiring diagram?

Are all fixings secure?

Are all relevant guards fitted?

Are all Circuit protection devices fitted?

Are all Terminal box covers and sealing glands secure?

Are all Earth connections secured?

Check that no hazard exists for persons in the locality of the fan. Switch on the fan and check that the fan rotation is correct as per the direction arrows on the fan plate/casing. If not isolate power supply and check wiring. For three phase fans interchange of any two phase leads on the supply will change rotation. Check that the current (amps) taken by the fan does not exceed the current shown on the rating plate.

INSTALLER AND ELECTRICAL CONTRACTOR RESPONSIBILITY

Vent-Axia, as suppliers of the equipment cannot be responsible for the final installation and electrical connection of the product on site. We have made reasonable effort to offer guidance and assistance but the installer and electrical contractor on site have a responsibility for ensuring the equipment is safely and securely installed and electrically/mechanically safe in accordance with statutory requirements.

The fans are supplied as a component to be incorporated into a ventilation system. The final complete system installation that includes the fans MUST meet the requirements of: -

Low voltage Directive 2014/35/EU

Machinery Directive 89/392/CE

Electromagnetic Compatibility Directive 2014/30/EU

If the fan is installed in an area where there is possible danger to safety or health then guards MUST be fitted.

Guards suitable for many applications are available from Vent-Axia Ltd.

Please remember that fans need maintenance, cleaning and inspection. Allow for reasonable access for these operations to be carried out safely.

If in doubt please ask.

ROUTINE INSPECTION/MAINTENANCE

THIS MUST BE UNDERTAKEN BY A COMPETENT PERSON.

ISOLATE UNIT FROM ELECTRICAL SUPPLY AND ENSURE THAT IT CANNOT BE ACCIDENTALLY TURNED BACK ON.

1. We recommend that after three months the fan should be inspected and cleaned to remove deposits on the impeller or motor. Thereafter, it should be checked and cleaned periodically as experience dictates, or at least twice a year.
2. If a build up of dirt/deposits is evident then this should be carefully cleaned off. Please take care not to damage the fan or affect the balance of the impeller motor assembly (balance weights may be fitted to the impeller).
3. The fan motors are fitted with 'sealed for life' bearings and should not require maintenance under normal circumstances.
4. The Ball-bearings service life – The according to standard calculation methods determined bearing service life expectation of the motor integrated ball bearings is mainly determined by the grease service life F10h and amounts for standard application to approx. 30.000 - 40.000 operating hours. The fan or motor is maintenance-free due to the use of ball bearings with "lifetime lubrication". Once the grease operating life F10h has been reached, it may be necessary to replace the bearing. The bearing service life expectation may change compared to the specified value, if operating conditions such as increased vibrations or shocks, increased or too low temperatures, humidity, dirt in the ball bearing or unfavourable control modes are present. A service life calculation for special applications can be provided on request.

Operation Conditions:

1. Duty type of motor/fan
Continuous operation with occasional starts (S1) according to DIN EN 60034-1:2011-02. Occasional starting between -40 °C and -25 °C is permissible. Continuous operation below -25 °C only with special bearings for refrigeration applications on request.
2. Permissible minimal and maximal ambient temperature for operation
Please refer to the technical documentation of the product for the minimum and maximum ambient temperature valid for the respective fan. Operation below -25 °C as well as partial load operation for refrigeration applications is only possible with special bearings for refrigeration applications on request. If special bearings for refrigeration applications are installed in the fan, please observe the permissible maximum temperatures in the technical documentation of the product.
3. Any use below -10 °C is dependent on not being subjected to unusual, sudden or mechanical loads or stresses on the material (see minimal permissible ambient temperature).

Wiring Diagrams:

Important Notes:- The electrical circuit must be protected with an all pole isolator having a minimum of 3mm contact separation with suitable fuses or circuit breaker.

For ducted applications the Thermal Protector (TB) must be connected into a control circuit in order to ensure that the fan cannot restart before the fault condition is cleared and the circuit manually reset.

(Refer to table below, for the relative wiring diagram – each fan has a wiring label within terminal box)

VA Part Number	Wiring Diagram	Air Flow Direction	Reversible (note if yes 40% reduction in airflow)	Voltage
ESC25012B	177X	A	NO	230
ESP25012B	177X	A	NO	230
ESC25014	177X	A	NO	230
ESP25014	177X	A	NO	230
ESC25032	106XB	A	NO	400
ESP25032	106XB	A	YES	400
ESC31532	106XB	A	YES	400
ESP31532	106XB	A	YES	400
ESC31512B	104XB	A	YES	230
ESP31512B	104XB	A	YES	230
ESC31534	106XB	A	YES	400
ESP31534	106XB	A	YES	400
ESC31514	104XB	A	YES	230
ESP31514	104XB	A	YES	230
ESC35514B	104XB	A	YES	230
ESP35514B	104XB	A	YES	230
ESP35516	104XB	A	YES	230
ESC35534	106XB	A	YES	400
ESP35534	106XB	A	YES	400
ESC40034	106XB	A	YES	400
ESP40034	106XB	A	YES	400
ESC40014B	104XB	A	YES	230
ESP40014B	104XB	A	YES	230
ESP40016B	104XB	A	YES	230
ESC45034	106XB	A	YES	400
ESP45034	106XB	A	YES	400
ESP45036	106XB	A	YES	400
ESC45014	104XB	A	YES	230
ESP45014	104XB	A	YES	230
ESC50034	106XB	A	YES	400
ESP50034	106XB	A	YES	400
ESC50014	104XB	A	YES	230
ESP50014	104XB	A	YES	230
ESC56034B	106XB	A	YES	400
ESP56034B	106XB	A	YES	400
ESC56014C	123XB	A	YES	230
ESP56014C	123XB	A	YES	230
ESP56036B	106XB	A	YES	400
ESP63016B	104XB	A	YES	230
ESC63034	106XB	A	YES	400
ESP63034	106XB	A	YES	400
ESC63014	104XB	A	YES	230
ESP63014	104XB	A	YES	230
ESC63036	106XB	A	YES	400
ESP63036	106XB	A	YES	400

VA Part Number	Wiring Diagram	Air Flow Direction	Reversible (note if yes 40% reduction in airflow)	Voltage
ESC71034	106XB	A	YES	400
ESP71034	106XB	A	YES	400
ESC71036	106XB	A	YES	400
ESP71036	106XB	A	YES	400
ESP71016	104XB	A	YES	230
ESC80036	106XB	A	YES	400
ESP80036	106XB	A	YES	400
ESP80038	106XB	A	YES	400
ESC100036	106XA	V	YES	400
ESP100036	106XB	A	YES	400
VSP25012A	177X	A	NO	230
VSP25014A	177X	A	NO	230
VSC31514B	177X	V	NO	230
VSC31534A	108XA	V	NO	400
VSP31514B	177X	A	NO	230
VSP31534A	108XB	V	NO	400
VSP35514B	177X	A	NO	230
VSC35534A	108XA	V	NO	400
VSP35534A	108XB	V	NO	400
VSC40014A	104XA	V	NO	230
VSP40014A	104XB	A	NO	230
VSC40034A	108XA	V	NO	400
VSP40034A	108XB	A	NO	400
VSC45014B	104XA	V	NO	230
VSC45034A	108XA	V	NO	400
VSC45036	108XA	V	NO	400
VSP45014B	104XB	A	NO	230
VSP45016B	104XB	A	NO	230
VSP45034A	108XB	V	NO	400
VSP45036	108XB	V	NO	400
VSC50014B	104XA	V	NO	230
VSP50014B	104XB	A	NO	230
VSP50016B	104XB	A	NO	230
VSC50034A	108XA	V	NO	400
VSP50034A	108XB	A	NO	400
VSC50036	108XA	V	NO	400
VSP50036A	108XB	A	NO	400
VSC56014B	104XB	A	NO	230
VSC56034A	108XA	V	NO	400
VSP56014B	104XB	A	NO	230
VSP56016B	104XB	A	NO	230
VSP56034A	108XB	A	NO	400
VSP56036	108XB	A	NO	400
VSP63014B	104XB	A	NO	230
VSP63016B	104XB	A	NO	230
VSP63034B	108XB	A	NO	400
VSP63036B	108XB	A	NO	400
VSC71016A	104XA	V	NO	230
VSP71016A	104XB	A	NO	230
VSP710368	108XB	A	NO	400
VSC35514B	177X	V	NO	230
VSC63014B	104XB	V	NO	230
VSC63034B	108XA	V	NO	400
VSC63036B	108XA	V	NO	400
VSC71036A	108XA	V	NO	400
VSP71036A	108XB	A	NO	400
VSP71038B	108XB	A	NO	400

104XA

1 ~ Motor with capacitor and thermostatic switch (if built in).

Airflow direction: V

Direction of rotation: Clockwise

Cable colours:

U1	Brown
U2	Blue
Z1	Black
Z2	Orange
TB	White

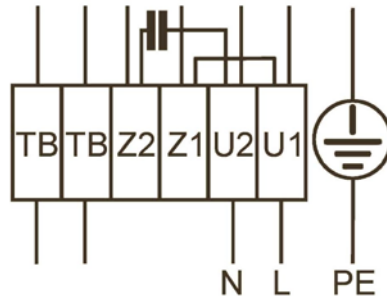

104XB

1 ~ Motor with capacitor and thermostatic switch (if built in).

Airflow direction: A

Direction of rotation: Counter clockwise

Cable colours:

U1	Brown
U2	Blue
Z1	Black
Z2	Orange
TB	White

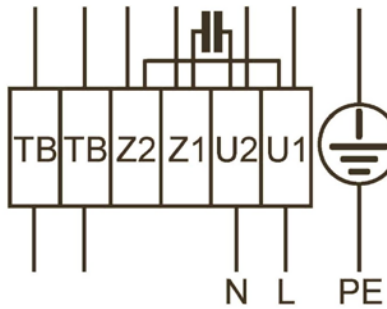

123XB

1 ~ Motor with capacitor and thermostatic switch (if built in).

Airflow direction: A

Direction of rotation: Counter clockwise

Cable colours:

U1	Brown
U2	Red
W1	Black
W2	Orange
V1	Blue
V2	Grey
TB	White

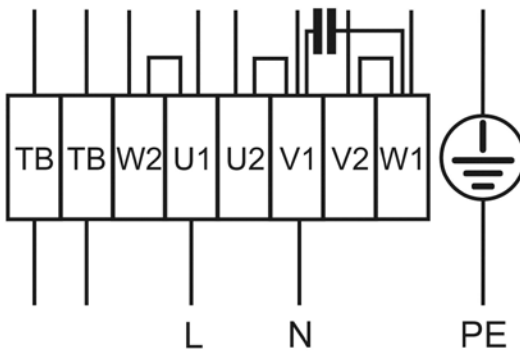

106XA

3 ~ Motor with one speed and

Δ -connection

Y-connection

thermostatic switch (if built in).

Airflow direction: V

Direction of rotation: Clockwise

Cable colours:

U1	Brown
V1	Blue
W1	Black
U2	Red
V2	Grey
W2	Orange
TB	White

Δ -connection

Y-connection

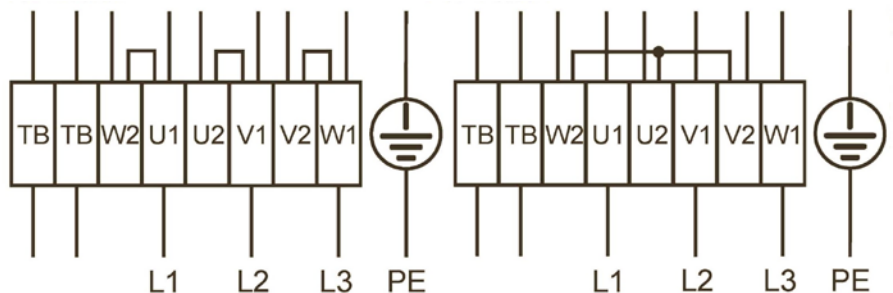

106XB

3 ~ Motor with one speed and
 Δ -connection
 Y-connection
 thermostatic switch (if built in).

Airflow direction: A

Direction of rotation: Counter clockwise

Cable colours:

U1	Brown
V1	Blue
W1	Black
U2	Red
V2	Grey
W2	Orange
TB	White

Δ -connection

Y-connection

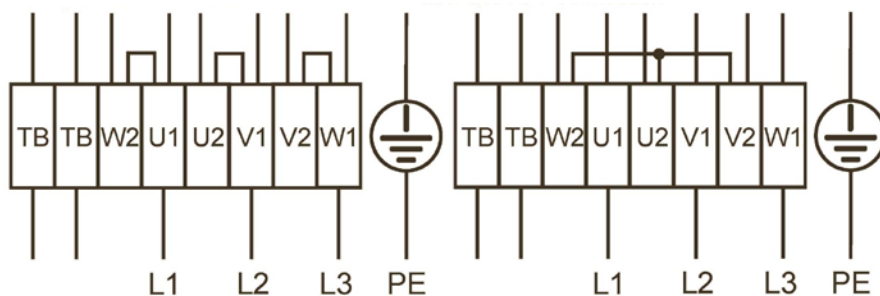

108XA

3 ~ Motor with 2 speeds
 High speed/ Δ -connection
 Low speed/Y-connection
 (Δ -/Y switch over) and
 thermostatic switch (if built in).
 Without bridge when using
 speed change-over switch.

Direction of airflow: V

Direction of rotation: Clockwise

Cable colours:

U1	Brown
V1	Blue
W1	Black
U2	Red
V2	Grey
W2	Orange
TB	White

High speed/ Δ -connection

Low speed/Y-connection

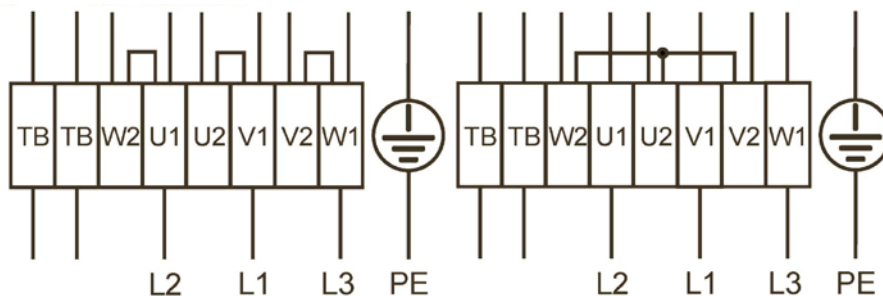

108XB

3 ~ Motor with 2 speeds
 High speed/ Δ -connection
 Low speed/Y-connection
 (Δ -/Y switch over) and
 thermostatic switch (if built in).
 Without bridge when using
 speed change-over switch.

Direction of airflow: A

Direction of rotation:

Counter clockwise

Cable colours:

U1	Brown
V1	Blue
W1	Black
U2	Red
V2	Grey
W2	Orange
TB	White

High speed/ Δ -connection

Low speed/Y-connection

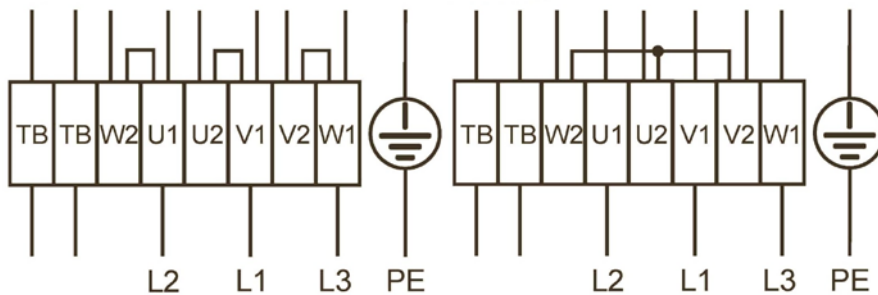

177X

1 ~ Motor with capacitor and thermostatic switch.

Other speeds possible with capacitor connected in series.

FN Series

Airflow direction: A

Direction of rotation: Counter-clockwise rotation (looking at rotor)

FB Series

Airflow direction: A

Direction of rotation: Clockwise rotation (looking at rotor)

Cable colours:

U2 Blue or Grey
Z2 Black
TB Brown

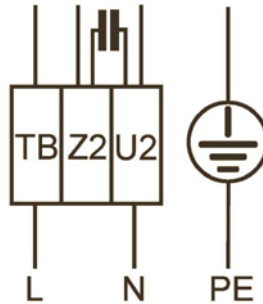

Fans supplied with a Separate Junction box, Please note the following information

1	Separate junction box made of plastic or metal
2	Lid Screws: - Tightening torque: Plastic box 1.3Nm/12 Lb In – Metal box 2.6Nm/23 Lb In
3	For cable glands see table below
4	Screw plugs, plastic/brass Tightening torque: 2.5 Nm/22 Lb In

Cable Gland Tightening torques

Thread size	Material	Tightening torques Ma	
M12 X 1.5	Plastic	1.5 Nm	13 Lb In
	Brass	4 Nm	35 Lb In
M16 X 1.5	Plastic	2.5 Nm	22 Lb In
	Brass	5 Nm	44 Lb In
M20 X 1.5	Plastic	4 Nm	35 Lb In
	Brass	6.5 Nm	58 Lb In
M25 X 1.5	Plastic	6.5 Nm	58 Lb In
	Brass	6.5 Nm	58 Lb In
M32 X 1.5	Plastic	6.5 Nm	58 Lb In



Vent-Axia[®]

Head Office: Fleming Way, Crawley, West Sussex, RH10 9YX. Tel: 01293 526062

EU Authorised Representative: Vent-Axia Sigarenmaker 5 - 5521DJ Eersel Nederland authorisedrep@vent-axia.nl

UK NATIONAL CALL CENTRE, Newton Road, Crawley, West Sussex, RH10 9JA

SALES ENQUIRIES: Tel: 0344 8560590

TECHNICAL SUPPORT: Tel: 0344 8560593



For details of the warranty and returns procedure please refer to www.vent-axia.com or write to Vent-Axia Ltd, Fleming Way, Crawley, RH10 9YX