

Lo-Carbon MVDC-MS/MSH Multivent

- Recognised in SAP PCDB with best in class Specific Fan Power
- Reduces your carbon footprint
- Fitted with three 125mm or nine 90mm diameter extract spigots allowing quick connection to ducts
- Complies with Building Regulations ADF
- Option of wall, ceiling and loft mounting
- Improved controllability
- Two Switched Live connections
- Fully variable normal, purge and boost speeds
- Ultra quiet
- Integral humidistat (H version)



With growing concerns about accurate ventilation of properties, the Lo-Carbon Multivent MVDC range offers the option of 'Close Control' both in the residential and the commercial sectors. With a DC motor the multi speed Lo-Carbon Multivent is one of the most efficient central extract units available.

The units have 3 fully variable speeds: normal, boost and purge. The digital display allows accurate setting of airflow, ensuring exactly the right ventilation rate. Accurate speed control helps minimise noise and energy consumption.

The Multivent H version incorporates a built-in humidity sensor to boost the unit when humidity reaches a certain threshold.

Models

Model	Stock Ref
MVDC-MS	437634
MVDC-MSH	443298
MVDC-MSH Uniflex	498502

SAP PCDB Test Results

Exhaust Terminal Configuration	Total Flow Rate (l/s)	SFP (W/l/s)
K + 1	21	0.15
K + 2	29	0.14
K + 3	37	0.16
K + 4	45	0.18
K + 5	53	0.21
K + 6	61	0.26

Dimensions (mm)

MVDC-MS/H

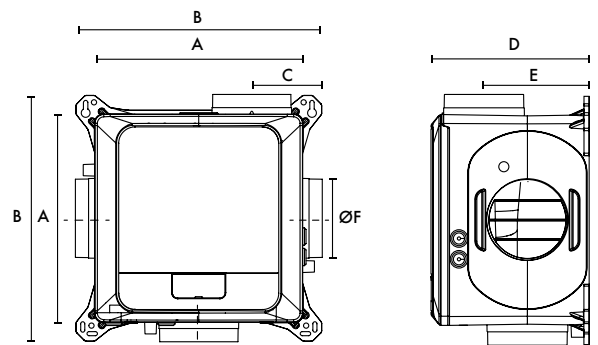

MVDC-MSH Uniflex

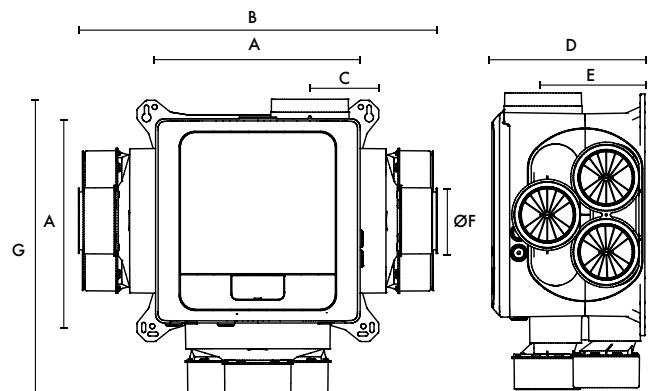

Model	A	B	C	D	E	ØF	G	kg	No. Extract Spigots
MVDC-MS/H	330	391	111	248	165	125	-	4.1	3
MVDC-MSH Uniflex	330	567	111	248	165	90	479	7	9

Performance Guide

MVDC-MSH features an integral humidistat which triggers the unit to boost when humidity levels in the duct system exceed 70%.

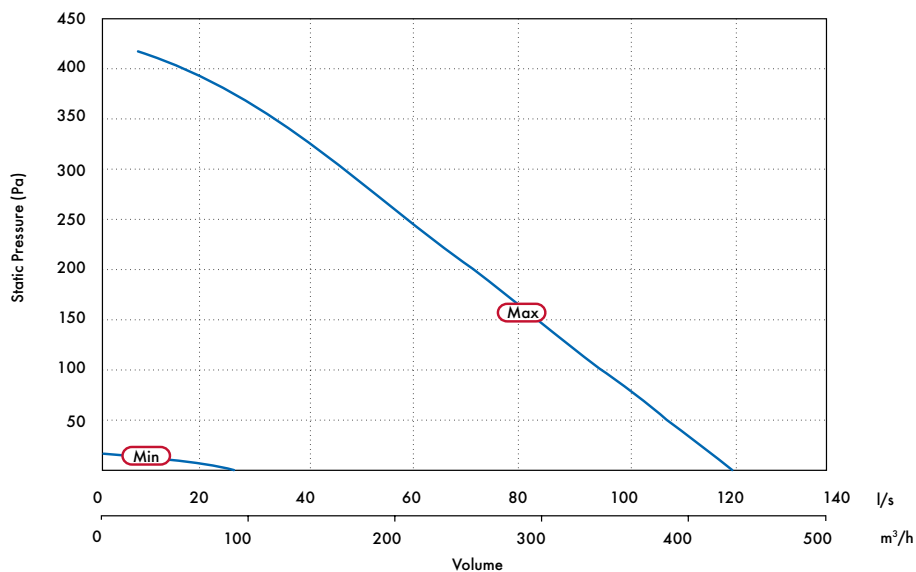

Min				Max				
Casing Breakout dB(A) @ 3m	Inlet Duct dB(A)	FID l/s	Power Watts	Casing Breakout dB(A) @ 3m	Inlet Duct dB(A)	FID l/s	Power Watts	SEC Class (inc. LDC)
13	18	24	2	37	40	118	44	B
13	18	24	2	37	40	118	44	B

Sound Data

Speed	Test Mode	Octave Band (Hz) Sound Power Levels, dB								LwA	SpL @ 3m
		63	125	250	500	1k	2k	4k	8k		
20%	Extract	50.3	40.4	40.0	33.7	28.1	21.6	18.0	23.0	36.2	18.7
	Breakout	40.2	38.7	32.8	26.9	17.1	14.5	17.8	22.4	29.9	9.4
40%	Extract	58.4	52.9	52.4	46.2	41.5	30.4	20.8	23.1	48.2	30.7
	Breakout	42.7	44.7	45.3	33.0	24.3	19.7	17.9	22.4	37.5	17.0
60%	Extract	56.4	58.2	62.5	53.9	41.3	40.0	32.0	25.9	56.2	38.7
	Breakout	40.1	52.1	50.2	39.2	30.6	32.2	20.0	22.4	43.9	23.4
80%	Extract	60.1	63.9	67.2	63.8	48.4	46.2	41.6	35.0	63.1	45.6
	Breakout	33.6	60.1	47.4	49.6	36.1	32.7	24.2	22.7	49.2	28.7
100%	Extract	76.2	79.3	71.9	69.7	53.6	51.4	47.9	42.2	69.7	52.2
	Breakout	47.3	56.6	52.5	52.7	40.7	37.7	29.7	23.7	51.7	31.2