

# High Temperature Roof Fan Range (RDM)

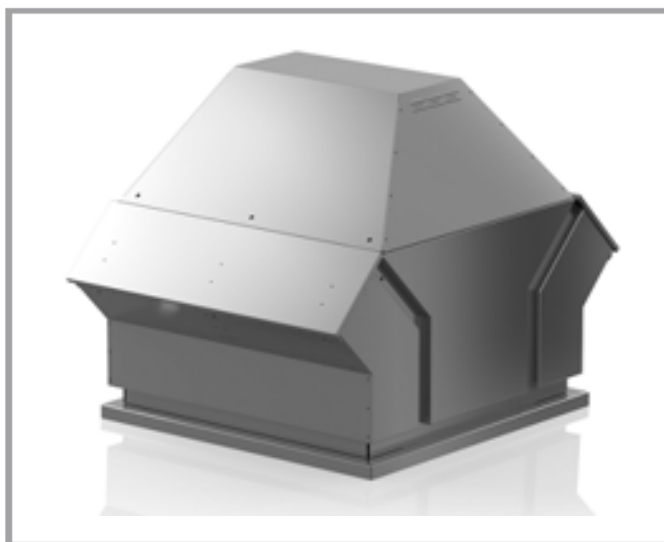

## Stock Ref No.

RDM3E25284D  
RDM3E25314D  
RDM3E35354D  
RDM3E354043  
RDM3E455043  
RDM3E455643  
RDM3E455663  
RDM3E566363  
RDMFE567163  
RDMFE718063  
RDMFE719063

380-415V / 3PH ~ 50Hz

***Vent-Axia***<sup>®</sup>

UK  
CA CE

PLEASE READ INSTRUCTIONS IN CONJUNCTION WITH ILLUSTRATIONS.  
PLEASE SAVE THESE INSTRUCTIONS.

---

# Contents

1. Contents.....	-2
2. About This Operating Manual .....	-3
3. Designated Use.....	-5
4. Safety .....	-6
5. Product Description.....	-9
6. Transport and Storage .....	-11
7. Installation .....	-12
8. Electrical Connection.....	-14
9. Commissioning / Operation.....	-16
10. Maintenance.....	-17
11. Faults.....	-18
12. Service, and Accessories.....	-19

---

## 2. About This Operating Manual



These operating instructions are an integral part of the roof fan. Vent-Axia Group Ltd shall not accept any liability or provide any warranty cover for primary damage or secondary damage arising as a consequence of disregarding these operating instructions.

- ▶ Read operating manual carefully before use.
- ▶ Retain operating manual for entire service life of roof fan. Keep operating manual accessible to personnel at all times.
- ▶ Pass operating manual on to any subsequent owner or user of roof fan.
- ▶ Insert any supplementary instructions received from the manufacturer in the operating manual.

### 2.1. Validity

This operating manual only applies to the roof fans stated on the front page.

### 2.2. Target Group

This operating manual is intended for operators and qualified professionals trained in installation, commissioning, operation, maintenance and decommissioning.

### 2.3. Other Applicable Documents

- ▶ In addition to reading these instructions, due notice should also be taken of the following documents and specifications on the roof fan:
  - IEC 60364/
  - DIN VDE 0100
  - DIN EN 60204-1
  - DIN EN ISO 13857
  - DIN EN ISO 12100
  - DIN EN ISO 13732-1
  - Type plate
  - Technical catalogue
  - Additional notes on roof fan (Warning Signs, Arrow Indicating Direction of Rotation)

### 2.4. Symbols and Markings

#### 2.4.1. Use of Warning Signs





Signal word

Nature, source and consequences of hazard!

- ▶ Steps required to avert danger

## 2.4.2. Levels of Danger in Warning Signs

Table 2-1: Levels of danger in warning signs

Symbol / Danger Level	Likelihood of Occurrence	Consequences of Neglect
 <b>DANGER</b>	Imminent danger	Death, serious physical injury
 <b>WARNING</b>	Potential danger	Death, serious physical injury
 <b>CAUTION</b>	Potential danger	Minor physical injury
<b>CAUTION</b>	Potential danger	Damage to property

## 2.4.3. Notes

### Note

Note giving pointers for easier or safe work.  
▶ Steps required for easier or safe work.

## 2.4.4. Other Symbols and Markings

Table 2-2: Other symbols and markings

Symbol	Meaning
☑	Requirement for an operation
▶	Operation with one step
1. .... 2. .... 3. ....	Operation with several steps
•	Bullet point (primary list)
-	Bullet point (secondary list)
<b>Accentuation (bold)</b>	For emphasis

### 3. Designated Use

#### 3.1. Operating Data / Maximum Ratings



##### Risk of injury!

- ▶ Adhere to technical specifications and permissible limits.

**For technical specifications reference should be made to the type plate, technical data sheet and technical catalogue.**

The roof fans are suitable for extracting dust-free air and other non-corrosive gases or vapours.

##### Permissible conveyed medium temperatures

Table 3-1: *Maximum ratings*

Range	Perm. temperature of conveyed medium	Max. ambient temp. on drive motor
RDM Roof Fan	-20°C to +120°C	+ 40°C

<sup>1)</sup> = Data depend on model; see full list "Roof fans".

**CAUTION**

##### Examples of incorrect use include the following:

- Extraction of media with impermissibly high or low temperatures
- Extraction of corrosive media
- Extraction of very dusty media
- Extraction of potentially explosive media.

**CAUTION**

##### Unauthorised operation

- No operation above the indicated rpm (see type plate, data sheet)
- No operation at rpm ranges with increased vibration (resonance)
- No operation at rpm ranges out of permitted fan curve area (stability of flow pattern)
- No operation if fan becomes polluted

**CAUTION**

##### Avoid dynamic load of the impeller.

**No frequent alteration of load (stop and go)!**

## 4. Safety

### 4.1. Product Safety

The fans offer a high degree of operational safety and high quality standards guaranteed by a certified Quality Management System (EN ISO 9001). Before leaving the factory all the fans are inspected and sealed with a mark of conformity.

Nevertheless, when operating roof fans supplied by Vent-Axia Group Ltd there can be a risk of death or injury for the user or third parties, and a risk of damage to the roof fan or other material assets.

- ▶ Only use roof fans in perfect working order and as intended, having due regard for safety, an awareness of hazards and in due compliance with the operating instructions.
- ▶ Arrange immediate repair of any faults which could compromise safety.



**The roof extract fans are delivered without inlet guards. If there is a danger of contact with the impeller owing to the way the fan is installed, then it is necessary to fit an inlet guard conforming to DIN EN ISO (available as an accessory). Only then the roof fan can be set in operation!**

### 4.2. Safety Instructions

- ▶ The roof fan may only be commissioned, operated and serviced in compliance with the following instructions:
  - Operating instructions
  - Warning and information signs on roof fan
  - Any other operating and installation instructions pertaining to the machine
  - Terms and requirements relevant to the machine
  - Applicable national and regional regulations, especially regarding health & safety and accident prevention.

### 4.3. Safety Devices

- ▶ Use appropriate safeguards to prevent contact with rotating parts (shafts, impeller, etc.).
- ▶ After installation (and before electrical connection) immediately refit any guards which have been removed during installation.

**CAUTION**

**The suitability of protection devices and their fixtures to the fan have to be evaluated within the complete security concept of the installation.**

## 4.4. Professional Staff

- ▶ Installation of roof fan and any work on it to be carried out by skilled professionals only with due regard to these operating instructions and any applicable regulations.
- ▶ Electrical connection to be carried out by qualified electricians only.

## 4.5. Protective Gear



CAUTION!

Ensure that members of staff are wearing protective gear appropriate to their deployment and environment.  
The protective clothing is specified below!

## 4.6. Specific Hazards

### 4.6.1. Noise Emission

The sound emission expected in normal use of the fan is documented in the technical lists and should be duly taken into account.



- ▶ **Wear ear defenders when working near to or on the running fan!**

### 4.6.2. Heavy Loads

The heavy weight of the roof fan and its components entail the following risks in transit and during installation:

- Risk of being trapped, crushed or cut by moving or toppling machinery
- Danger of falling components
- ▶ **Do not stand or work under suspended loads**
- ▶ **Wear a hard hat, safety shoes and gloves**



### 4.6.3. Rotating Shafts and Impellers

Objects falling onto rotating shafts and impellers can fly off at an angle and cause serious injury.

Articles of clothing and hair can get caught in rotating shafts and impellers.



- ▶ **Do not remove guards during operation**
- ▶ **Do not wear loose-fitting clothing when working near rotating shafts and impellers**
- ▶ **Wear goggles**

**Caution electrical hazard!**

**Electrical potential at intermediate circuit of Driver and power connections if the permanent magnet motor rotates!**



- do not work at the fan if the impeller/motor is not locked
- lock fan impeller by proper means

#### 4.6.4. Hot Surfaces



There is a risk of sustaining burns or scalds on hot surfaces during operation.

- ▶ **Do not touch the motor during operation**
- ▶ **When the roof fan has stopped wait until the motor has cooled down**
- ▶ **Wear protective gloves**

#### 4.7. Structural Modifications, Spare Parts

**Note** **Unauthorised structural modifications may not be made to the roof fan without the consent of Vent-Axia Group Ltd. Vent-Axia Group Ltd shall not accept liability for any damage arising as a result of said modifications. Use only genuine spare parts supplied by Vent-Axia Group Ltd.**

#### 4.8. Installation and Maintenance

- ▶ The following steps should be taken before working on the roof fan:
  - Switch off the machine and take measures to prevent it from being switched back on accidentally.
  - Display the following message on a sign:  
**Do not switch on! Work currently in progress on the machine**

#### 4.9. Signs on the Roof Fan

Depending on the model, the type plate and the arrow indicating the direction of rotation are fitted to the housing or handle for high visibility.



## 5. Product Description

### 5.1. General Information on Roof Fans



**DANGER**

All the roof fans are delivered ready for connection and are protected by an outlet guard conforming to DIN EN ISO 13857. Inlet guards are not fitted as standard. If there is a danger of contact with the impeller owing to the way the fan is installed, then it is necessary to fit an inlet guard conforming to DIN EN ISO 13857 (available as an accessory).

### Roof Fans with Built-On Motor

#### 5.2. RDM 3E/FE Fans

Centrifugal roof fan, vertical discharge, with standard IEC motor outside airstream with external air cooling. Aluminium casing and galvanized sheet steel structure.

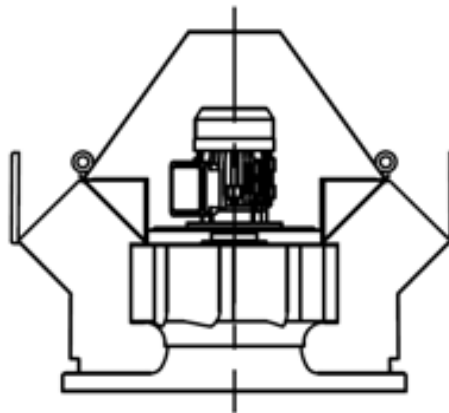

### **5.3. Motor Protection**

#### **Models RDM3E/ RDMFE**

The motors used in RDM 3E/FE - 4D/43/63 models are fitted with thermal contacts.

They switch the motor off automatically when it has reached a set maximum temperature and switch it back on again automatically when it has cooled down.

## 6. Transport and Storage



### 6.1. Packaging

Roof fans are packaged in sturdy cardboard boxes or wooden crates depending on their size and weight.

### 6.2. Symbols on Packaging

The following symbols are printed on the cardboard boxes:

Table 6-1: Symbols on packaging

Symbol			
Meaning	Handle with care	Keep dry	Top

### 6.3. Transportation of Roof Fan



Danger of injury from falling components!

- ▶ Use tested and appropriate load handling equipment only (see type plate or data sheet).
- ▶ Lift the roof fan by the base frame and/or by the eyelet rings only.
- ▶ Secure load.
- ▶ Do not stand under suspended loads.

**CAUTION**

**The casing may be damaged by lifting!**

The roof fans listed below should always be lifted by the eyelet rings using a lifting device and spacer crossbar.

Lifting device and spacer crossbar for roof fans:

- RDM FE-718063 and 719063
1. Select means of transport according to weight and dimensions of fan.
  2. Lift roof fan at the lifting points provided (see packaging).
  3. Secure load using e.g. straps or other aids designed to prevent slipping.
  4. Transport roof fan with care and avoid damage caused by e.g. knocks and hitting the ground hard at an angle.



Fig 6-1:  
Lifting device

### 6.4. Storage of Roof Fan

**CAUTION**

**Risk of corrosion!**

- ▶ Store the fan in its packaging, adding any other protection dictated by its storage environment.
- ▶ Store roof fan in a well-ventilated room only at normal temperatures and in a non-corrosive atmosphere.
- ▶ Store roof fan in conditions registering less than 70 % atmospheric humidity.
- ▶ Adhere to max. permissible temperature of  $-20^{\circ}\text{C}$  to  $+40^{\circ}\text{C}$ .

## 7. Installation

### 7.1. Safety Instructions for Installation

- ▶ Observe the safety instructions and preventive measures in Chapter 4 and the relevant legal requirements.

### 7.2. Installation Preparation

- ☑ Place of installation suitable for the roof fan in terms of its category, condition, ambient temperature and environmental media.
- ☑ Base level and with sufficient load-bearing capacity.
- ☑ Place of installation horizontal (installation permissible on surfaces with angles of inclination of up to max. 20°).

**Note** In the case of the roof fans listed below the two discharge openings opposite each other should be placed at right angles to the pitch.

- RDM 3E/FE

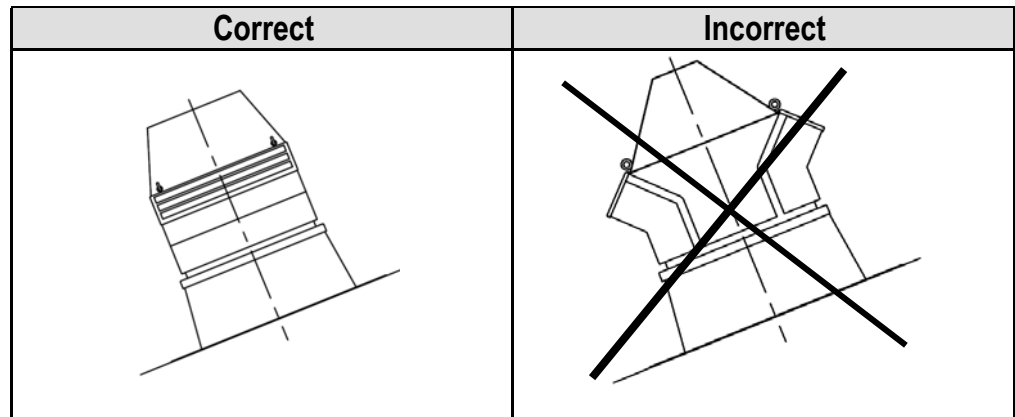

Fig 7-1:  
Installation direction

- ☑ Unpack the roof fan carefully.
- ☑ Remove all the packaging and dispose of it correctly.

### 7.3. Carrying out Installation

The roof fans are designed for mounting on a base.  
There are four holes in the base frame for fixing to the roof base.

**Access to the fixing holes:**

RDM 3E /FE

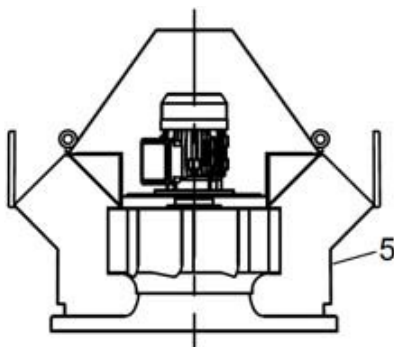

Remove side panel (5)

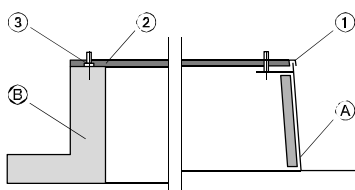

Fig7-2: Roof base

**A** Flat roof upstand (accessories)

1 Sealing lip (supplied with Flat roof upstand)

**B** Wall base (on site)

2 Sealant (on site)

3 Spacer disc (on site)

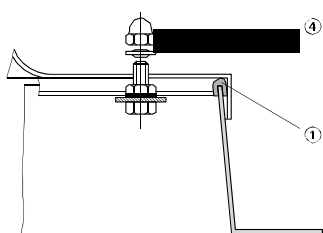

Fig 7-3: Sealing

1. Place sealing lip (1) and sealing tape (2) on the base (for airtight bed).
2. Place the roof fan complete with mounting plate on the base (A and B).
3. Insert connecting cable but do not connect.
4. Mount sealing washers (4) (plastic) under the base fixing bolts.
5. Tighten base screws evenly.
6. Rotate impeller by hand ensuring that it runs smoothly and freely.
7. If applicable, refit side panels on fan.

**Note** Use adjustable connecting sleeves to connect to ducting!

- No forces or vibrations transferred to the roof fan from plant parts!
- The stability against collapse of the fan has been checked!

**CAUTION**

**Warping impedes smooth running of impeller and causes fatigue fractures!**

- ▶ Avoid uneven tightening of base screws.
- ▶ Install roof fan so as to guarantee its stability at all times during operation.

## 7.4. Installing Safety Devices

**Note**

Conformity with DIN EN ISO 13857 only relates to the safety guard installed in so far as it is supplied with the fan.  
The operator of the system is responsible for full compliance with DIN EN ISO 13857.

1. Fit guards to protect exposed inlet openings (DIN EN ISO 13857).
2. Design safety devices in such a way that they prevent objects from being sucked in or from falling in.
3. Ensure that all the mechanical safety devices are fitted.

## 8. Electrical Connection

### 8.1. Safety Instructions for Electrical Connection



Caution! Danger of electric shock!

- ▶ Observe the safety instructions and preventive measures in Chapter 4 and the relevant legal requirements.
- ▶ EN 60204

### 8.2. Connecting the Motor

**Note**

All the roof fans are delivered ready for connection. The terminal box and inspection switch are located under the cowl and housing cover respectively. The connection diagram is located in the terminal box.

**Note**

The system should always be evaluated in its entirety and specific application in terms of assessing whether it conforms to the applicable EMC standards and directives.

This is the responsibility of the customer.

Separate EMC protective measures may be required with the combination of revision switches and frequency converters.

- Current, voltage and frequency of mains supply checked for conformity with fan type plate and motor rating plate.
- Star-delta or soft start provided for motors with a nominal output >4 kW.

- Inspection switch present if applicable.

Table 8-1:  
General diagram of roof fans

- |   |                              |   |            |
|---|------------------------------|---|------------|
| 1 | Cowl                         | 5 | Side panel |
| 2 | Cable duct                   |   |            |
| 3 | Terminal box                 |   |            |
| 4 | Inspection switch (optional) |   |            |

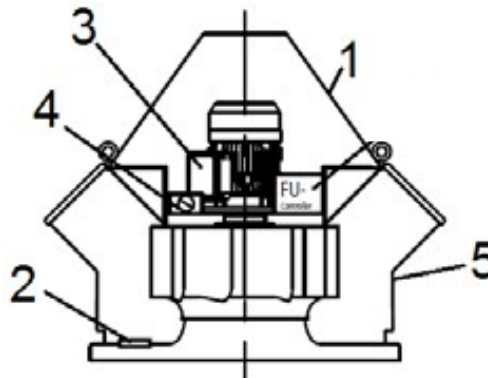

RDM 3E / FE

1. Remove cowl (1).
2. Lock the impeller for highly efficient permanent magnet motors **Measures taken to prevent roof fan from starting suddenly.** Remove side panels on following models
3.
  - 3.1. RDM 3E/RDM FE models remove side panel (5)
4. Run connection cable through cable duct in base frame (2) to terminal box (3) or inspection switch (4).
5. On RDM 3E/RDM FE models lay mains power cable loosely to allow the central section to be swung back easily.
6. In the vicinity of the impeller fix the cable to the support arm with cable clips (RDM 3E/RDM FE), and fix the cable to the guard and/or handle using cable ties.
7. Refit outer side panels (RDM 3E/RDM FE).
8. Connect motor as shown on connection diagram supplied resp.
9. Fit cowl (1).
10. Ensure that all the electrical safety devices have been fitted and connected.
11. Connect motors with a nominal output >4 kW to star-delta or soft start.

## 8.3. Carrying out a Test Run



**DANGER**

Risk of injury from rotating impeller!

- ▶ Never reach into the impeller when the fan is open.

1. Disconnect motor / frequency inverter from the mains.
2. Take measures to prevent roof fan from being switched on accidentally.
3. Clear the ducting system and fan of all foreign bodies (tools, small parts, construction waste, etc.).
4. Close all the inspection openings.
5. Switch on fan and check direction of rotation of impeller by comparing it with the arrow on the fan indicating the direction of rotation.
6. If the direction of rotation is wrong, reverse the polarity of the motor.
7. Once operating speed has been reached measure the current consumption and compare it with the nominal motor current on the roof fan motor rating plate.
8. If there is continuous overload, switch the roof fan off immediately.
9. Check that the roof fan runs smoothly and quietly. Ensure that there are no unusual oscillations or vibrations.
10. Check the motor for any abnormal noises.

## 9. Commissioning / Operation

The motors are designed for continuous operation S1. If operations involve more than three starts per hour Vent-Axia Group Ltd shall be required to confirm the suitability of the motor.

### 9.1. Commissioning the Roof Fan



**DANGER**

**Risk of injury from rotating parts and hot surfaces!**

- ▶ Ensure that all the safety devices are fitted!
- ▶ Ensure that the impeller has been secured acc. to DIN EN ISO 13857!

**CAUTION**

**Material damage may be caused by overload from excessive starting currents!**

- ▶ Adhere to the output limits imposed by the power supply company.

**Course of action**

1. Check working order of all control instruments connected.
2. Switch on roof fan.



## 10. Maintenance

### 10.1. Safety Instructions for Maintenance

- ▶ Observe the safety instructions and preventive measures in Chapter 4 and the relevant legal requirements.
- ▶ Follow the directions of the motor supplier and the instructions specified by the manufacturers of the switches and control units.

### 10.2. Maintenance Preparation

1. Disconnect motor from the mains.
2. Roof fans fitted with an inspection switch should be switched off by means of the inspection switch.
3. Take measures to prevent roof fan from being switched on accidentally.
4. Wait until the impeller has stopped.
5. Wait until all hot surfaces have cooled down.
6. Remove any residues from the fan.

### 10.3. Tilting the RDM 3E/RDM FE Roof Fan Up / Back



Risk of injury from roof fan falling back suddenly from tilted position!

- ▶ Take measures to prevent roof fan from swinging back.

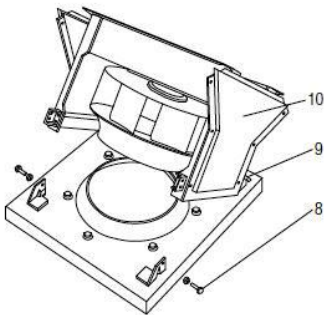

Fig 10-1: Tilting mechanism

#### Tilting up

- Side panels removed, cowl removed
- 1. Remove screws (8).
- 2. Tilt back central section (10).
- 3. Secure central section on both sides using screws (8) and nuts in articulated joint (9).

#### Tilting back (after servicing)

1. Prop up tilted roof fan (release locking screws).
2. Remove locking screws from articulated joint (9) and lower roof fan carefully down out of tilted position.
3. Insert and tighten fixing bolts (8).

## 10.4. Observing Regular Inspection Intervals

In the interests of upkeep and safety we recommend having the operation and condition of the fans inspected at regular intervals by duly qualified service personnel or a professional maintenance firm and documenting these inspections.

The nature and extent of the maintenance work, the service intervals and any additional work required needs to be specified on a case-by-case basis depending on the use of the fans and the general conditions on site.

- Maintenance preparation completed
- Roof fan tilted up and secured (RDM)

### **CAUTION**

#### **Pressure washers can cause damage to property!**

- ▶ Do not use pressure washers (steam jet cleaners) to clean the equipment.

#### **Maintenance recommendations for roof fans:**

- ▶ Conduct test run if applicable (see Chapter 8.3).
- ▶ Document inspection intervals observed.

### **CAUTION**

**If the state of the fan does not allow adapted action for repair it has to be put out of order immediately and to be replaced if required.**

## 11. Faults

If faults occur during operation which cannot be repaired by maintenance personnel please contact the service department of Vent-Axia Group Ltd.

### **CAUTION**

#### **Roof fan may be damaged by improper operating states!**

- ▶ Switch the roof fan off immediately if permissible limits are exceeded and in the event of irregularities or faults.

## 12. Service, and Accessories

Vent-Axia Group Ltd  
Crawley, England  
RH10 9YX

Tel.: 0844 856 0591  
Fax: 01293 534898  
Mail: [Sales@Vent-Axia.com](mailto:Sales@Vent-Axia.com)  
[www.vent-axia.com](http://www.vent-axia.com)

### 12.1. Accessories

Vent-Axia Group Ltd has a wide range of accessories for economic and efficient use of the fans.

Accessories are optional and always need to be ordered separately.

#### **Flat Roof upstands**

475776 - RDM3E25  
475777 – RDM3E35  
475778 - RDM3E45  
475779 – RDM3E56 /FE56  
475780 – RDMFE71

#### **Inclined Roof upstands**

475787 - RDM3E25  
475788 – RDM3E35  
475789 - RDM3E45  
475790 – RDM3E56 /FE56  
475791 – RDMFE71

(Note:- Please specify roof pitch required in degrees at point of order. They are available in 5,10,15,20,25,30,35,40 & 45 degrees).

#### **Intake flexible connection**

475798 - RDM3E25  
475799 – RDM3E35  
475800 - RDM3E45  
475801 – RDM3E56 /FE56  
475802 – RDMFE71

#### **Protection grid for intake**

475809 - RDM3E25  
475810 – RDM3E35  
475811 - RDM3E45  
475812 – RDM3E56 /FE56  
475813 – RDMFE71

#### **Inlet Silencer**

475820 - RDM3E25  
475821 – RDM3E35  
475822 - RDM3E45  
475823 – RDM3E56 /FE56  
475824 – RDMFE71

# **Vent-Axia**

Head Office: Fleming Way, Crawley, West Sussex, RH10 9YX.

EU Authorised Representative: Vent-Axia Bedrijvenweg 17 7442 CX Nijverdal Nederland [authorisedrep@vent-axia.nl](mailto:authorisedrep@vent-axia.nl)

**UK NATIONAL CALL CENTRE**, Newton Road, Crawley, West Sussex, RH10 9JA

SALES ENQUIRIES: Tel: 0844 8560591 Fax: 01293 565169

TECHNICAL SUPPORT: Tel: 0844 8560593 Fax: 01293 539209

For details of the warranty and returns procedure please refer to [www.vent-axia.com](http://www.vent-axia.com) or write to Vent-Axia Ltd, Fleming Way, Crawley, RH10 9YX

476867B

0321